

GA150 Antenna

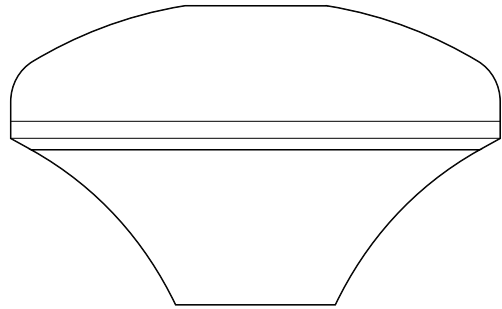

Installation instructions

English

Date: 05-2015

Document number: 87230-2-EN

© 2015 Raymarine UK Limited

Trademark and patents notice

Raymarine, Tacktick, Clear Pulse, Truzoom, HSB, SeaTalk, SeaTalk^{hs}, SeaTalk^{ng}, Micronet, Raytech, Gear Up, Marine Shield, Seahawk, Autohelm, Automagic, and Visionality are registered or claimed trademarks of Raymarine Belgium.

FLIR, DownVision, SideVision, Dragonfly, Instalert, Infrared Everywhere, and The World's Sixth Sense are registered or claimed trademarks of FLIR Systems, Inc.

All other trademarks, trade names, or company names referenced herein are used for identification only and are the property of their respective owners.

This product is protected by patents, design patents, patents pending, or design patents pending.

Fair Use Statement

You may print no more than three copies of this manual for your own use. You may not make any further copies or distribute or use the manual in any other way including without limitation exploiting the manual commercially or giving or selling copies to third parties.

Software updates

Check the website www.raymarine.com for the latest software releases for your product.

Product handbooks

The latest versions of all English and translated handbooks are available to download in PDF format from the website www.raymarine.com.

Please check the website to ensure you have the latest handbooks.

Copyright ©2015 Raymarine UK Ltd. All rights reserved.

Contents

Chapter 1 Important information.....	7
Certified Installation	7
Water ingress	7
Disclaimer	7
EMC installation guidelines	7
Suppression ferrites	7
Connections to other equipment	8
Declaration of conformity.....	8
Product disposal.....	8
Warranty registration.....	8
IMO and SOLAS.....	8
Technical accuracy	8
Chapter 2 Document and product information.....	9
2.1 Document information	10
2.2 GA150 Parts supplied.....	10
2.3 GA150 product overview	11
Chapter 3 Planning the installation	13
3.1 Installation checklist	14
3.2 GA150 MFD compatibility	14
3.3 Tools required	15
3.4 Warnings and cautions	15
3.5 Antenna location requirements.....	16
3.6 Product dimensions.....	16
Chapter 4 Cables and connections.....	17
4.1 General cabling guidance	18
4.2 Connections overview	19
Chapter 5 Mounting.....	21
5.1 Fitting the antenna	22
5.2 Surface mounting.....	22
5.3 Pole mounting.....	23
Chapter 6 System checks and troubleshooting	25
6.1 Operation instructions.....	26
6.2 Troubleshooting	27
Chapter 7 Maintenance	29
7.1 Routine checks	30
7.2 Unit cleaning instructions.....	30
Chapter 8 Technical support	31
8.1 Raymarine customer support	32
Chapter 9 Technical specification.....	33
9.1 Technical specification.....	34

Chapter 1: Important information

Certified Installation

Raymarine recommends certified installation by a Raymarine approved installer. A certified installation qualifies for enhanced product warranty benefits. Contact your Raymarine dealer for further details, and refer to the separate warranty document packed with your product.



Warning: Product installation and operation

This product must be installed and operated in accordance with the instructions provided. Failure to do so could result in personal injury, damage to your vessel and/or poor product performance.



Warning: Potential ignition source

This product is NOT approved for use in hazardous/flammable atmospheres. Do NOT install in a hazardous/flammable atmosphere (such as in an engine room or near fuel tanks).



Warning: Switch off power supply

Ensure the vessel's power supply is switched OFF before starting to install this product. Do NOT connect or disconnect equipment with the power switched on, unless instructed in this document.

Caution: Service and maintenance

This product contains no user serviceable components. Please refer all maintenance and repair to authorized Raymarine dealers. Unauthorized repair may affect your warranty.

Water ingress

Water ingress disclaimer

Although the waterproof rating capacity of this product meets the stated IPX standard (refer to the product's *Technical Specification*), water intrusion and subsequent equipment failure may occur if the product is subjected to commercial high-pressure washing. Raymarine will not warrant products subjected to high-pressure washing.

Disclaimer

Raymarine does not warrant that this product is error-free or that it is compatible with products manufactured by any person or entity other than Raymarine.

Raymarine is not responsible for damages or injuries caused by your use or inability to use the product, by the interaction of the product with products manufactured by others, or by errors in information utilized by the product supplied by third parties.

EMC installation guidelines

Raymarine equipment and accessories conform to the appropriate Electromagnetic Compatibility (EMC) regulations, to minimize electromagnetic interference between equipment and minimize the effect such interference could have on the performance of your system

Correct installation is required to ensure that EMC performance is not compromised.

Note: In areas of extreme EMC interference, some slight interference may be noticed on the product. Where this occurs the product and the source of the interference should be separated by a greater distance.

For **optimum** EMC performance we recommend that wherever possible:

- Raymarine equipment and cables connected to it are:
 - At least 1 m (3 ft) from any equipment transmitting or cables carrying radio signals e.g. VHF radios, cables and antennas. In the case of SSB radios, the distance should be increased to 7 ft (2 m).
 - More than 2 m (7 ft) from the path of a radar beam. A radar beam can normally be assumed to spread 20 degrees above and below the radiating element.
- The product is supplied from a separate battery from that used for engine start. This is important to prevent erratic behavior and data loss which can occur if the engine start does not have a separate battery.
- Raymarine specified cables are used.
- Cables are not cut or extended, unless doing so is detailed in the installation manual.

Note: Where constraints on the installation prevent any of the above recommendations, always ensure the maximum possible separation between different items of electrical equipment, to provide the best conditions for EMC performance throughout the installation

Suppression ferrites

- Raymarine cables may be pre-fitted or supplied with suppression ferrites. These are important for correct EMC performance. If ferrites are supplied separately to the cables (i.e. not pre-fitted), you must fit the supplied ferrites, using the supplied instructions.
- If a ferrite has to be removed for any purpose (e.g. installation or maintenance), it must be replaced in the original position before the product is used.

- Use only ferrites of the correct type, supplied by Raymarine or its authorized dealers.
- Where an installation requires multiple ferrites to be added to a cable, additional cable clips should be used to prevent stress on the connectors due to the extra weight of the cable.

our policy of continuous product improvement may change specifications without notice. As a result, Raymarine cannot accept liability for any differences between the product and this document. Please check the Raymarine website (www.raymarine.com) to ensure you have the most up-to-date version(s) of the documentation for your product.

Connections to other equipment

Requirement for ferrites on non-Raymarine cables

If your Raymarine equipment is to be connected to other equipment using a cable not supplied by Raymarine, a suppression ferrite **MUST** always be attached to the cable near the Raymarine unit.

Declaration of conformity

Raymarine UK Ltd. declares that this product is compliant with the essential requirements of R&TTE directive 1999/5/EC.

The original Declaration of Conformity certificate may be viewed on the relevant product page at www.raymarine.com.

Product disposal

Dispose of this product in accordance with the WEEE Directive.



■ The Waste Electrical and Electronic Equipment (WEEE) Directive requires the recycling of waste electrical and electronic equipment.

Warranty registration

To register your Raymarine product ownership, please visit www.raymarine.com and register online.

It is important that you register your product to receive full warranty benefits. Your unit package includes a bar code label indicating the serial number of the unit. You will need this serial number when registering your product online. You should retain the label for future reference.

IMO and SOLAS

The equipment described within this document is intended for use on leisure marine boats and workboats NOT covered by International Maritime Organization (IMO) and Safety of Life at Sea (SOLAS) Carriage Regulations.

Technical accuracy

To the best of our knowledge, the information in this document was correct at the time it was produced. However, Raymarine cannot accept liability for any inaccuracies or omissions it may contain. In addition,

Chapter 2: Document and product information

Chapter contents

- [2.1 Document information on page 10](#)
- [2.2 GA150 Parts supplied on page 10](#)
- [2.3 GA150 product overview on page 11](#)

2.1 Document information

This document contains important information related to the installation of your Raymarine product.

The document includes information to help you:

- plan your installation and ensure you have all the necessary equipment;
- install and connect your product as part of a wider system of connected marine electronics;
- troubleshoot problems and obtain technical support if required.

This and other Raymarine product documents are available to download in PDF format from www.raymarine.com.

Applicable products

This document is applicable to the following products:

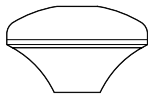
	Part number	Name	Description
	A80288	GA150	GNSS (GPS / GLONASS) antenna

Document illustrations

Your product may differ slightly from that shown in the illustrations in this document, depending on product variant and date of manufacture.

All images are provided for illustration purposes only.

Product documentation

The following documentation is applicable to your product:

Description	Part number
GA150 Installation instructions Installation of a GA150 antenna and connection to a compatible MFD.	87230 / 88038
GA150 Surface mount template Mounting diagram for surface mounting a GA150.	87224
LightHouse™ Operation instructions Describes the operation and configuration of all LightHouse™ MFDs..	81360

2.2 GA150 Parts supplied

The parts supplied with your GA150 GNSS (GPS / GLONASS) antenna are shown below.

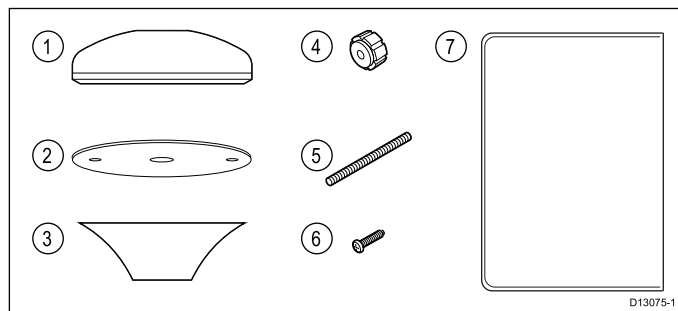

1. GA150 antenna (The antenna is supplied with a fitted 10 m (33 ft.) cable for connection to your MFD.)
2. GA150 mounting gasket
3. Pole mount adaptor
4. 2 x Thumbs nuts
5. 2 x Studs
6. 2 x screws
7. Document pack

2.3 GA150 product overview

The GA150 is an external antenna capable of improving the reception of a Multifunction display's (MFD's) internal Global Navigation Satellite System (GNSS) receiver.

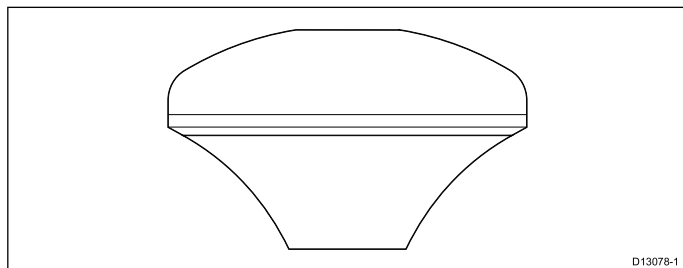

The GA150 has the following features:

- 10 m (33 ft.) fitted cable.
- Low power consumption.
- Surface or pole mountable.

Note: When the Beidou GNSS becomes available a GA150 MUST be used in order to obtain reception. Your MFD will also require a software update to enable support of the Beidou system.

Chapter 3: Planning the installation

Chapter contents

- [3.1 Installation checklist on page 14](#)
- [3.2 GA150 MFD compatibility on page 14](#)
- [3.3 Tools required on page 15](#)
- [3.4 Warnings and cautions on page 15](#)
- [3.5 Antenna location requirements on page 16](#)
- [3.6 Product dimensions on page 16](#)

3.1 Installation checklist

Installation includes the following activities:

Installation Task	
1	Plan your system.
2	Obtain all required equipment and tools.
3	Site all equipment.
4	Route all cables.
5	Drill cable and mounting holes.
6	Make all connections into equipment.
7	Secure all equipment in place.
8	Power on and test the system.

Schematic diagram

A schematic diagram is an essential part of planning any installation. It is also useful for any future additions or maintenance of the system. The diagram should include:

- Location of all components.
- Connectors, cable types, routes and lengths.

3.2 GA150 MFD compatibility

The GA150 antenna is compatible with the following Raymarine® LightHouse™ MFDs:

- **a Series** a95 / a97 / a98 / a125 / a127 / a128.
- **eS Series** eS97 / eS98 / eS127 / eS128

Multifunction display software requirements

The operation of this product requires a Raymarine® MFD running LightHouse™ software.

Raymarine® MFD variant	LightHouse™ software requirement
a Series a95 / a97 / a98 / a125 / a127 / a128	Version 11 or later
eS Series eS97 / eS98 / eS127 / eS128	Version 14 or later

3.3 Tools required

Product installation requires the following tools:

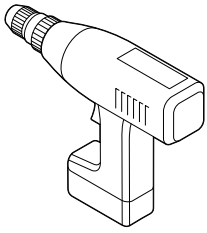
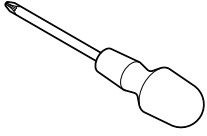
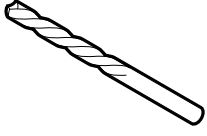
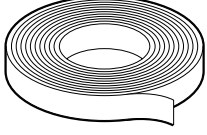
Item	Description	Quantity
	Power drill	1
	Pozidrive screwdriver	1
	Drill bit of appropriate size*	1
	Adhesive tape	1

Note: * The appropriate drill bit size is dependent on the thickness and material of the mounting surface.

3.4 Warnings and cautions

Important: Before proceeding, ensure that you have read and understood the warnings and cautions provided in the [Chapter 1 Important information](#) section of this document.

3.5 Antenna location requirements

The antenna can be used to improve the reception of your MFD's built-in GNSS (GPS / GLONASS) receiver. Do NOT connect any other antenna to the MFD's GA150 connector.

The antenna can be mounted either on a flat horizontal surface or on a suitable pole.

- If you intend to surface mount the antenna, ensure you have access to the underside of the mounting surface.
- If you intend to pole-mount the antenna, the pole needs to have a 1 inch 14 TPI thread.

Important: The antenna must be mounted in a location that provides a good direct line of site to the entire sky, around the horizon.

Ensure that the selected mounting location is:

- Open and clear of any obstructions (such as masts, search lights, or other structures) that could block line-of-sight to the sky.
- As low as possible, to keep the antenna as stable as possible. The more stable the antenna, the more effectively it will track satellites and provide stable data.
- As far as possible (at least 1 m (3 ft) from other antennae and electronic equipment.

Do NOT mount the antenna:

- In any area where it could be stepped on or tripped over.
- Up a mast. This will cause the antenna to swing and give significant errors in position data.
- In the direct path of a radar beam.

Antenna Mounting & EME Exposure

For optimal radio performance and minimal human exposure to radio frequency electromagnetic energy, make sure the antenna is:

- connected to the radio before transmitting
- properly mounted
- located where it will be away from people
- located at least 1.5 metres (5 feet) from the radio's main unit

3.6 Product dimensions

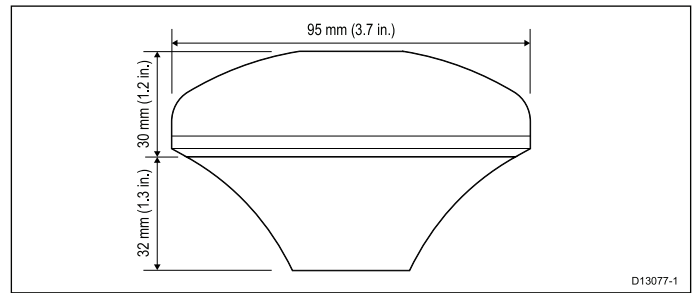

Chapter 4: Cables and connections

Chapter contents

- [4.1 General cabling guidance on page 18](#)
- [4.2 Connections overview on page 19](#)

4.1 General cabling guidance

Cable types and length

It is important to use cables of the appropriate type and length

- Unless otherwise stated use only standard cables of the correct type, supplied by Raymarine.
- Ensure that any non-Raymarine cables are of the correct quality and gauge. For example, longer power cable runs may require larger wire gauges to minimize voltage drop along the run.

Routing cables

Cables must be routed correctly, to maximize performance and prolong cable life.

- Do NOT bend cables excessively. Wherever possible, ensure a minimum bend diameter of 200 mm (8 in) / minimum bend radius of 100 mm (4 in).

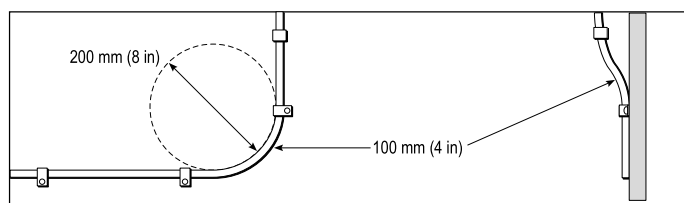

- Protect all cables from physical damage and exposure to heat. Use trunking or conduit where possible. Do NOT run cables through bilges or doorways, or close to moving or hot objects.
- Secure cables in place using tie-wraps or lacing twine. Coil any extra cable and tie it out of the way.
- Where a cable passes through an exposed bulkhead or deckhead, use a suitable watertight feed-through.
- Do NOT run cables near to engines or fluorescent lights.

Always route data cables as far away as possible from:

- other equipment and cables,
- high current carrying ac and dc power lines,
- antennae.

Strain relief

Ensure adequate strain relief is provided. Protect connectors from strain and ensure they will not pull out under extreme sea conditions.

Cable shielding

Ensure that all data cables are properly shielded that the cable shielding is intact (e.g. hasn't been scraped off by being squeezed through a tight area).

Suppression ferrites

- Raymarine cables may be pre-fitted or supplied with suppression ferrites. These are important for correct EMC performance. If ferrites are supplied separately to the cables (i.e. not pre-fitted), you must fit the supplied ferrites, using the supplied instructions.

- If a ferrite has to be removed for any purpose (e.g. installation or maintenance), it must be replaced in the original position before the product is used.
- Use only ferrites of the correct type, supplied by Raymarine or its authorized dealers.
- Where an installation requires multiple ferrites to be added to a cable, additional cable clips should be used to prevent stress on the connectors due to the extra weight of the cable.

Connections to other equipment

Requirement for ferrites on non-Raymarine cables

If your Raymarine equipment is to be connected to other equipment using a cable not supplied by Raymarine, a suppression ferrite **MUST** always be attached to the cable near the Raymarine unit.

4.2 Connections overview

GA150 MFD compatibility

The GA150 antenna is compatible with the following Raymarine® LightHouse™ MFDs:

- **a Series** a95 / a97 / a98 / a125 / a127 / a128.
- **eS Series** eS97 / eS98 / eS127 / eS128

Multifunction display software requirements

The operation of this product requires a Raymarine® MFD running LightHouse™ software.

Raymarine® MFD variant	LightHouse™ software requirement
a Series a95 / a97 / a98 / a125 / a127 / a128	Version 11 or later
eS Series eS97 / eS98 / eS127 / eS128	Version 14 or later

GA150 connection

If your **MFD** has a **GA150** connection, the external antenna can be connected to help improve the GNSS (GPS / GLONASS) receiver's reception.

Refer to the *Connection Overview* section to establish if your **MFD** can be connected to a **GA150**.

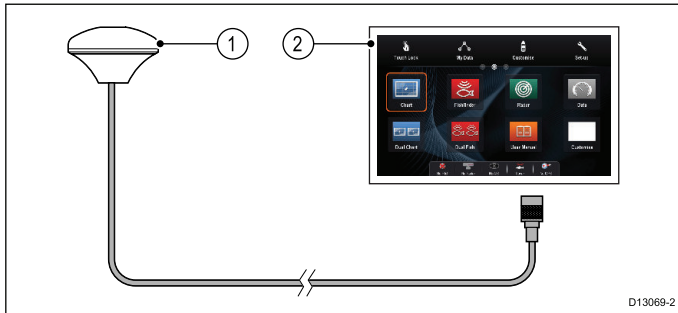

1. GA150 external antenna
2. **MFD**

For installation details for your external antenna, refer to the documentation that accompanied the antenna.

Antenna cable length

The GA150 is supplied with a fitted 10 m (33 ft.) cable. The length of the antenna cable can be extended if required.

The antenna cable length can be extended by up to 10 m (33 ft.) giving a total maximum cable length of 20 m (66 ft.)

50 ohm coaxial cable and reliable connectors (offering protection against water ingress) must be used when extending the antenna cable.

Note: Extending the cable length by more than the recommended maximum length will result in signal degradation.

Connecting an external antenna

Follow the steps below to connect the GA150 external antenna.

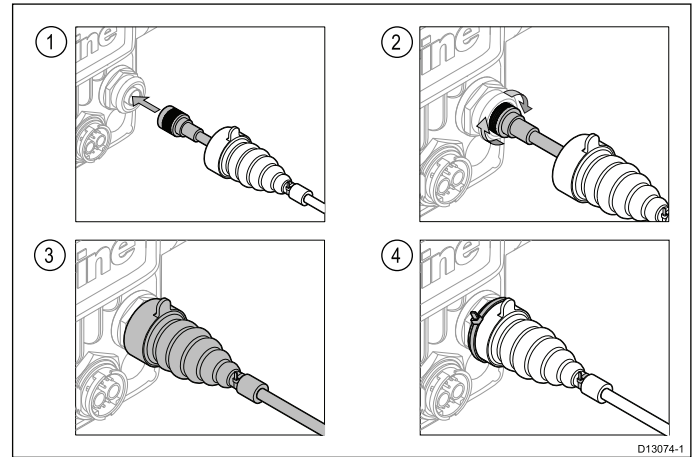

1. Fully insert the antenna's cable connector into the GA150 connector on the rear of your display.
2. Turn the locking collar clockwise until **TIGHT**.
3. Push to protective boot over the connection on the back of the display.
4. Use the supplied cable tie to secure the protective boot over the connection.

Chapter 5: Mounting

Chapter contents

- [5.1 Fitting the antenna on page 22](#)
- [5.2 Surface mounting on page 22](#)
- [5.3 Pole mounting on page 23](#)

5.1 Fitting the antenna

To fit the antenna:

1. Select a suitable location for the antenna as described under *Antenna location requirements*.
2. Fit your antenna using either the *Surface mounting* or *Pole mounting* procedure, as appropriate.
3. Ensuring that cable routing and connection requirements as detailed in the installation instructions for the product that the antenna will be connected to are followed.

5.2 Surface mounting

When surface mounting the antenna, you can route the cable either centrally (Option A) or from the side of the antenna (Option B).

1. Use the template supplied to mark the two 6 mm (0.25 in) mounting holes.
 - OPTION A: If the cable is going to pass through the mounting surface drill a 19 mm (0.75 in) center hole.
 - OPTION B: If the cable is to be routed from the side of the antenna (i.e. above the mounting surface), remove the two plastic tabs (1) obstructing the cable channel. If you do not remove these tabs before using the cable channel, you could damage the cable.

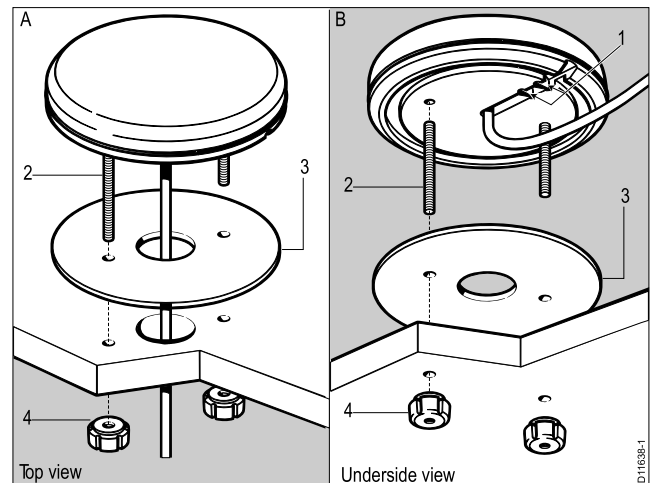

2. Screw the two mounting studs (2) into the underside of the antenna.
3. Stick the supplied gasket (3) to the mounting surface, ensuring that the holes on the gasket correspond with the drilled holes.
4. Route the cable as follows:
 - For Option A, feed the cable down through the center hole.
 - For Option B, route the cable along the cable exit channel.
5. Carefully place the antenna so the mounting studs pass through the holes in the mounting surface.
6. Secure the antenna to the surface using the supplied thumb nuts (4).

5.3 Pole mounting

If you want to pole-mount the antenna, obtain a pole of suitable length with a 1 inch 14 TPI thread.

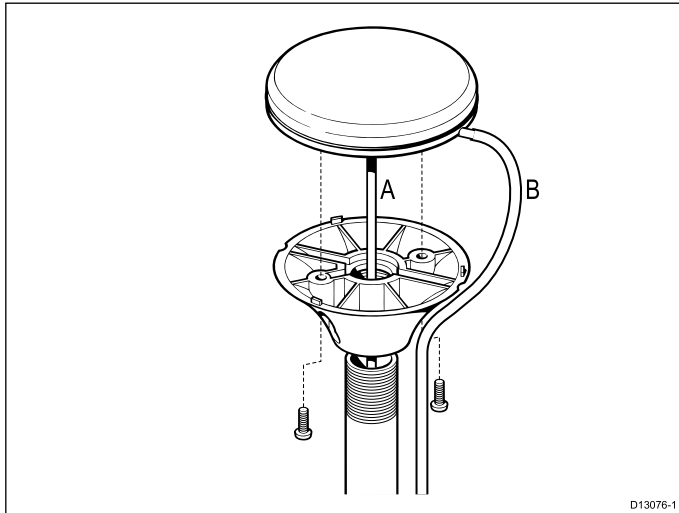

1. Ensuring that the *Antenna location requirements* are met, securely attach the pole to a suitable, stable point.
2. Screw the pole mount adaptor fully onto the pole and ensure it is secure on the pole.
3. Route the antenna cable as follows:
 - i. If you want to route the antenna cable directly down from the antenna (option A), feed it through the center of the pole mount adaptor and then down through the pole.
 - ii. If you want to route the antenna cable out of the side of the antenna (option B), remove the two plastic tabs from the cable channel, then feed the cable along the channel.
4. Ensuring you do not trap the cable, place the antenna on the pole mount adaptor so the screw holes align, then secure the antenna with the screws provided.

Chapter 6: System checks and troubleshooting

Chapter contents

- [6.1 Operation instructions on page 26](#)
- [6.2 Troubleshooting on page 27](#)

6.1 Operation instructions

For detailed operation instructions for your product, refer to the documentation that accompanies your display.

6.2 Troubleshooting

The troubleshooting information provides possible causes and corrective action required for common problems associated with marine electronics installations.

All Raymarine products are, prior to packing and shipping, subjected to comprehensive test and quality assurance programs. However, if you experience problems with the operation of your product this section will help you to diagnose and correct problems in order to restore normal operation.

If after referring to this section you are still having problems with your unit, please contact Raymarine Technical Support for further advice.

GPS troubleshooting

Problems with the GPS and their possible causes and solutions are described here.

Problem	Possible causes	Possible solutions
"No Fix" GPS status icon is displayed.	Geographic location or prevailing conditions preventing satellite fix.	Check periodically to see if a fix is obtained in better conditions or another geographic location.
	GPS connection fault.	Ensure that external GPS connections and cabling are correct and fault free.
	External GPS antenna in poor position. For example: <ul style="list-style-type: none">• Below decks.• Close proximity to transmitting equipment such as VHF radio.	Ensure GPS antenna has a clear view of the sky.
	GPS installation problem.	Refer to the installation instructions.

Note: A GPS Status screen is available within the display. This provides satellite signal strength and other relevant information.

Chapter 7: Maintenance

Chapter contents

- [7.1 Routine checks on page 30](#)
- [7.2 Unit cleaning instructions on page 30](#)

7.1 Routine checks

The following periodic checks should be made:

- Examine cables for signs of damage, such as chafing, cuts or nicks.
- Check that the cable connectors are firmly attached and that their locking mechanisms are properly engaged.

Note: Cable checks should be carried out with the power supply switched off.

7.2 Unit cleaning instructions

The unit does not require regular cleaning. However, if you find it necessary to clean the unit, please follow the steps below:

1. Ensure power is switched off.
2. Wipe unit clean with a damp cloth.
3. If necessary, use a mild detergent solution to remove grease marks.

Chapter 8: Technical support

Chapter contents

- [8.1 Raymarine customer support on page 32](#)

8.1 Raymarine customer support

Raymarine provides a comprehensive customer support service. You can contact customer support through the Raymarine website, telephone and e-mail. If you are unable to resolve a problem, please use any of these facilities to obtain additional help.

Web support

Please visit the customer support area of our website at:

www.raymarine.com

This contains Frequently Asked Questions, servicing information, e-mail access to the Raymarine Technical Support Department and details of worldwide Raymarine agents.

Telephone and e-mail support

In the USA:

- **Tel:** +1 603 324 7900
- **Toll Free:** +1 800 539 5539
- **E-mail:** support@raymarine.com

In the UK, Europe, and the Middle East:

- **Tel:** +44 (0)13 2924 6777
- **E-mail:** ukproduct.support@raymarine.com

In Southeast Asia and Australia:

- **Tel:** +61 (0)29479 4800
- **E-mail:** aus.support@raymarine.com

Product information

If you need to request service, please have the following information to hand:

- Product name.
- Product identity.
- Serial number.
- Software application version.
- System diagrams.

You can obtain this product information using the menus within your product.

Chapter 9: Technical specification

Chapter contents

- [9.1 Technical specification on page 34](#)

9.1 Technical specification

Physical specification

Dimensions	<ul style="list-style-type: none">• Diameter: 95 mm (3.7 in.)• Height: 30 mm (1.2 in.)• Height (including pole mount adaptor): 62 mm (2.5 in.)
Weight	<ul style="list-style-type: none">• Boxed weight 0.74 Kg (1.6 lbs)• Unboxed weight (including cable): 0.5 Kg (1.1 lbs)

Environmental specification

Operating temperature	0°C to +55°C (+32°F to +131°F)
Storage temperature	-30°C to +70°C (-22°F to +158°F)
Relative humidity	95%
Waterproof rating	IPX6 and IPX7

Conformance specification

Conformance	<ul style="list-style-type: none">• EN 60945:2002• R&TTE Directive 1999/5/EC• Australia and New Zealand: C-Tick, Compliance Level 2
--------------------	---

Raymarine[®]
BY  **FLIR**[®]