



NEMESIS™

QUICK GUIDES

3	ENGLISH	23	FRANÇAIS	43	PORTUGUÊS
8	DEUTSCH	28	ITALIANO	48	SVENSKA
13	ESPAÑOL	33	NEDERLANDS	53	中文
18	SUOMI	38	NORSK		



About this document

This document describes the basic operation of the unit.

Turning the system ON/OFF

The unit will turn ON when power is applied.

First time startup

When you start the unit for the first time or after a factory reset, the unit displays a setup wizard. The wizard will guide you through the set up of the screen orientation, language, and other settings.

→ **Note:** Any settings made during the first time set up can be changed later from the system settings.

Lock/unlock the screen

By default, the screen is automatically locked when the unit is idle for a period of time. This screen lock feature can be changed in the system settings.

When the dashboard bar is shown, press the lock button to lock the screen.

To unlock the screen, if installed in landscape orientation swipe from the right edge of the display. If installed in portrait orientation swipe from the bottom of the display.

Landscape orientation



Portrait orientation



Landscape orientation



Portrait orientation



Home screen

The Home screen is accessed by selecting the Home button.

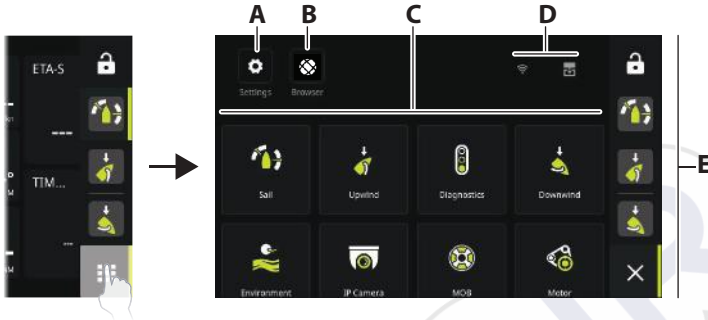

- A** Settings button - gives access to the system settings.
- B** Browser button - can be used to access the B&G® CPU web server or for browsing the internet.
- C** Dashboards - select the dashboard that you want to activate, or select the new dashboard option to create a custom dashboard.
- D** Status bar
- E** Dashboard bar - pinned and recently used dashboards.

Dashboard bar



- A** Lock button
 - B** Pinned dashboards - user favorite dashboards.
 - C** Recently used dashboard.
 - D** Home button
- **Note:** The active item in the dashboard bar will be highlighted.

Pin/unpin a dashboard

Pin a dashboard

On the home screen, press and hold on the dashboard that you want to pin to the dashboard bar. You can pin a dashboard to a new position or overwrite existing position on the dashboard bar.

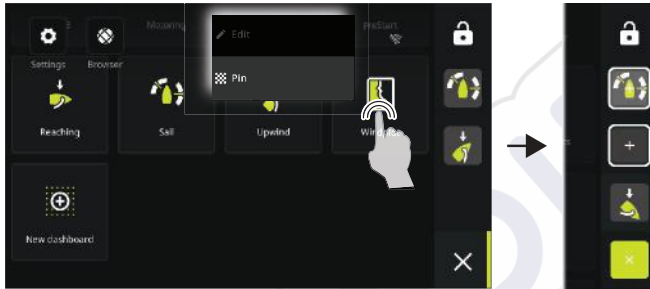

Unpin a dashboard

From the dashboard bar, press and hold to display the unpin option.



Dashboards

Swipe left/right to change between pinned dashboards.

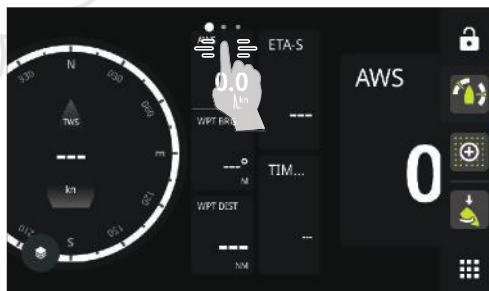

Edit and delete a dashboard

On the home screen, press and hold on the dashboard you want to edit or delete.

→ **Note:** Some options might not be available depending on the selected dashboard.

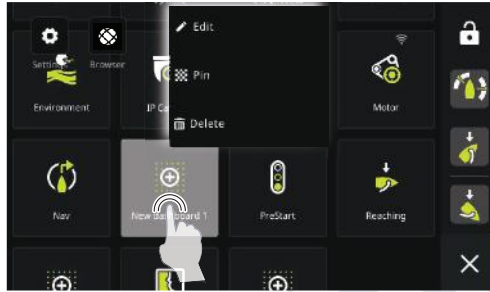

Customize gauge settings

Gauges included in a dashboard can be customized. Press and hold on the gauge to display the edit options.

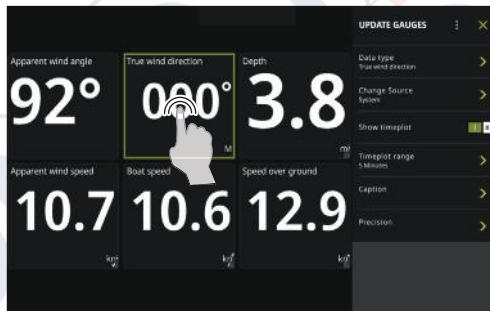

Create a new dashboard

→ **Note:** You can start from a blank dashboard, a template, or from a saved dashboard. A saved dashboard is one of your previous dashboards you have created.

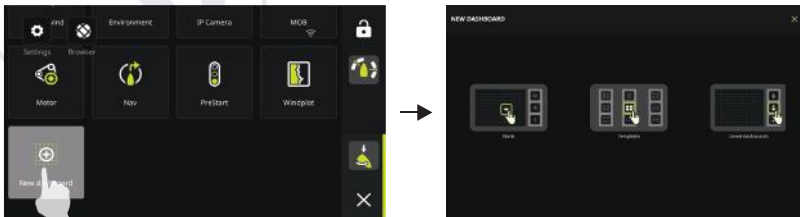



- A** Change gauge settings, choose data to be shown on the gauge.
- B** Resize gauge.
- C** Change dashboard attributes.

System settings

The system settings is accessed from the home screen.

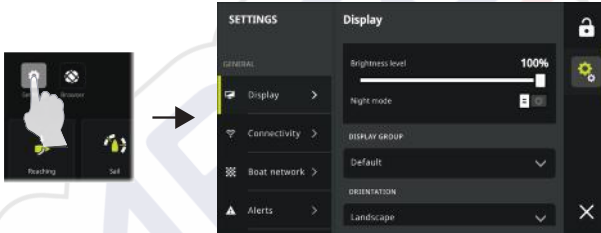

Quick access menu

Use the Quick access menu to change the screen brightness, activate night/day mode, or to report an issue.

Access the menu by swiping from the top edge of the display.

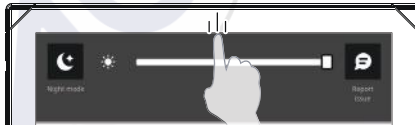

Product manuals

For the latest information and updated documentation refer to the website: www.bandg.com.

Über dieses Dokument

In diesem Dokument werden die Grundlagen zur Bedienung des Systems beschrieben.

Ein-/Ausschalten des Systems

Das System schaltet sich ein, sobald die Versorgungsspannung anliegt.

Erstmaliges Einschalten

Wenn Sie das Gerät zum ersten Mal einschalten bzw. auf die Werkseinstellungen zurücksetzen, zeigt das Gerät einen Setup-Assistenten an. Der Assistent führt Sie durch die Einrichtung des Bildschirms sowie der Sprach- und anderer Einstellungen.

→ **Hinweis:** Alle Einstellungen, die bei der ersten Einrichtung vorgenommen wurden, können später über die Systemeinstellungen geändert werden.

Sperren/Entsperren des Bildschirms

Standardmäßig wird der Bildschirm automatisch gesperrt, wenn das Gerät eine gewisse Zeit lang nicht benutzt wird. Diese Bildschirmssperrfunktion kann in den Systemeinstellungen geändert werden.

Wenn die Dashboard-Leiste angezeigt wird, drücken Sie die Sperrtaste, um den Bildschirm zu sperren.

Um den Bildschirm zu entsperren, wischen Sie vom rechten Rand des Displays zum linken, wenn der Bildschirm im Querformat eingerichtet ist. Wenn der Bildschirm im Hochformat eingerichtet ist, wischen Sie von unten nach oben über das Display.

Querformat



Hochformat



Querformat



Hochformat



Startseite

Über die Schaltfläche Home können Sie auf die Startseite zugreifen.

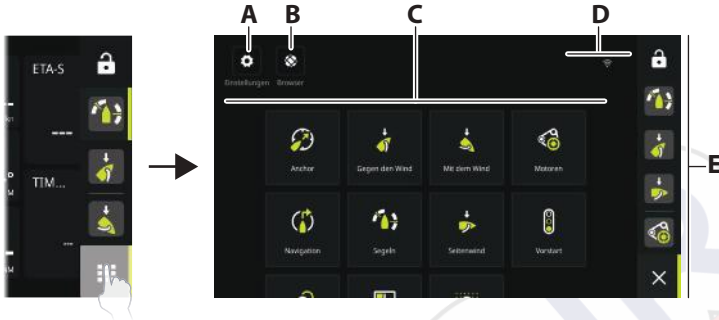

- A** Über die Schaltfläche Einstellungen können Sie auf die Systemeinstellungen zugreifen.
- B** Über die Schaltfläche Browser können Sie auf den B&G® CPU-Webserver zugreifen oder im Internet surfen.
- C** Über die Schaltfläche Dashboards können Sie das Dashboard auswählen, das Sie aktivieren möchten, oder die Option Neues Dashboard auswählen, um ein benutzerdefiniertes Dashboard zu erstellen.
- D** Statusleiste
- E** In der Dashboard-Leiste finden Sie angeheftete und zuletzt verwendete Dashboards.

Dashboard-Leiste



- A** Sperrtaste
 - B** Angeheftete Dashboards sind die vom Benutzer bevorzugten Dashboards.
 - C** Zuletzt verwendetes Dashboard.
 - D** Schaltfläche Home
- **Hinweis:** Das in der Dashboard-Leiste aktivierte Element wird hervorgehoben.

Anheften/Lösen eines Dashboards

Anheften eines Dashboards

Halten Sie auf der Startseite das Dashboard gedrückt, das Sie an die Dashboard-Leiste anheften möchten. Sie können ein Dashboard an eine neue Position anheften oder die vorhandene Position auf der Dashboard-Leiste überschreiben.

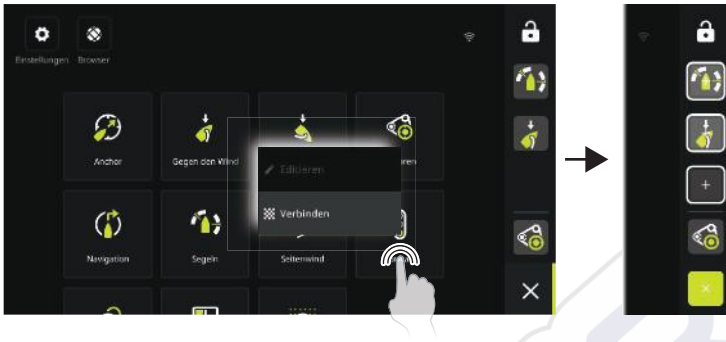

Lösen eines Dashboards

Halten Sie das Dashboard in der Dashboard-Leiste gedrückt, um die Option Lösen anzuzeigen.

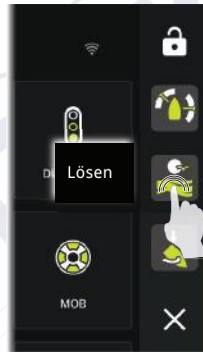

Armaturen

Wischen Sie nach links/rechts, um zwischen angehefteten Dashboards zu wechseln.

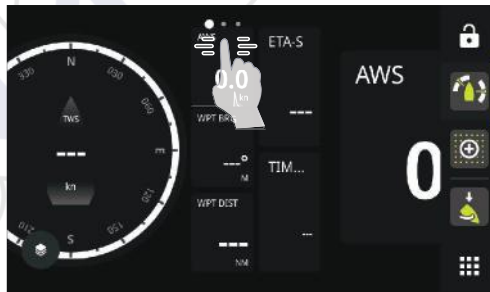

Bearbeiten und Löschen eines Dashboards

Halten Sie auf der Startseite das Dashboard gedrückt, das Sie bearbeiten oder löschen möchten.

→ **Hinweis:** Je nach ausgewähltem Dashboard sind einige Optionen ggf. nicht verfügbar.



Anpassen der Anzeigeeinstellungen

Dashboard-Anzeigen können angepasst werden. Halten Sie die Anzeige gedrückt, um ihre Bearbeitungsoptionen anzuzeigen.



Erstellen eines neuen Dashboards

→ **Hinweis:** Nehmen Sie ein leeres Dashboard, eine Vorlage oder ein gespeichertes Dashboard als Ausgangspunkt. Ein gespeichertes Dashboard ist eines Ihrer zuvor erstellen Dashboards.

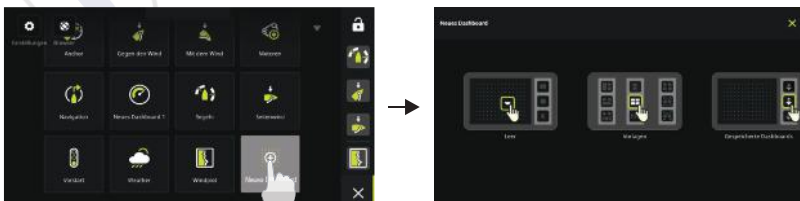



- A** Ändern Sie die Anzeigeeinstellungen, und wählen Sie die Daten aus, die in der Anzeige dargestellt werden sollen.
- B** Ändern Sie die Anzeigegröße.
- C** Ändern Sie Dashboard-Attribute.

Systemeinstellungen

Der Zugriff auf die Systemeinstellungen erfolgt über die Startseite.

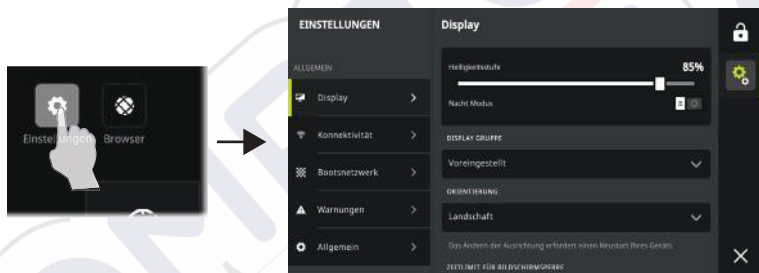

Schnellzugriff-Menü

Verwenden Sie das Schnellzugriff-Menü, um die Bildschirmhelligkeit zu ändern, den Nacht-/Tag-Modus zu aktivieren oder ein Problem zu melden.

Wischen Sie über das Display von oben nach unten, um auf das Menü zuzugreifen.

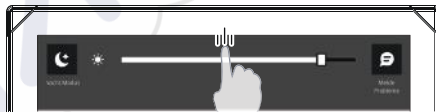

Produktbücher

Weitere Informationen finden Sie auf der Website:

www.bandg.com.

Acerca de este documento

Este documento describe el funcionamiento básico de la unidad.

Encendido y apagado del sistema

La unidad se encenderá cuando se conecte la alimentación eléctrica.

Primer encendido

Al encender la unidad por primera vez o después de restablecer los valores de fábrica, la unidad muestra un asistente de configuración. El asistente le guiará para configurar el idioma, la orientación de la pantalla y otros ajustes.

→ **Nota:** Los ajustes realizados durante la primera configuración se pueden cambiar más adelante desde los ajustes del sistema.

Bloqueo y desbloqueo de la pantalla

De forma predeterminada, la pantalla se bloquea automáticamente cuando la unidad lleva inactiva un periodo de tiempo. Esta función de bloqueo de pantalla se puede cambiar en los ajustes del sistema.

Cuando se muestre la barra del panel de instrumentos, pulse el botón de bloqueo para bloquear la pantalla.

Para desbloquear la pantalla, si está instalada en orientación horizontal, deslice el dedo desde el borde derecho de la pantalla. Si está instalada en orientación vertical, deslice el dedo desde la parte inferior de la pantalla.

Orientación
horizontal



Orientación
vertical



Orientación
horizontal

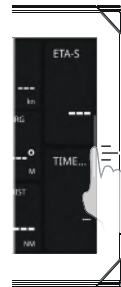

Orientación
vertical



Pantalla de inicio

Es posible acceder a la pantalla de inicio seleccionando el botón de inicio.

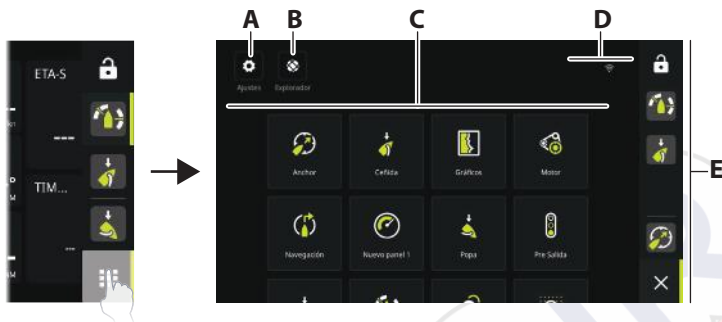

- A** Botón de ajustes: permite acceder a los ajustes del sistema.
- B** Botón del navegador: se puede utilizar para acceder al servidor web B&G® CPU o para navegar por Internet.
- C** Paneles de instrumentos: seleccione el panel de instrumentos que desea activar o seleccione la opción de panel de instrumentos nuevo para crear uno personalizado.
- D** Barra de estado
- E** Barra del panel de instrumentos: paneles de instrumentos anclados y utilizados recientemente.

Barra del panel de instrumentos

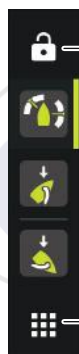

- A** Botón de bloqueo
 - B** Paneles de instrumentos anclados: los favoritos del usuario.
 - C** Paneles de instrumentos utilizados recientemente.
 - D** Botón de inicio
- **Nota:** Se resaltará el elemento activo de la barra del panel de instrumentos.

Anclar y desanclar un panel de instrumentos

Anclar un panel de instrumentos

En la pantalla de inicio, mantenga pulsado el panel de instrumentos que desea anclar a la barra del panel de instrumentos. Puede anclar un panel de instrumentos a una nueva posición o sobrescribir la posición existente en la barra del panel de instrumentos.



Desanclar un panel de instrumentos

Mantenga pulsada la barra del panel de instrumentos para mostrar la opción desanclar.

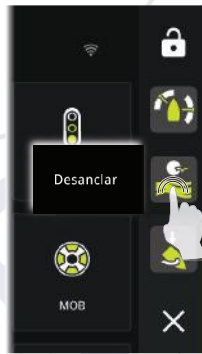

Paneles de instrumentos

Deslice el dedo hacia la izquierda o la derecha para cambiar entre paneles de instrumentos anclados.

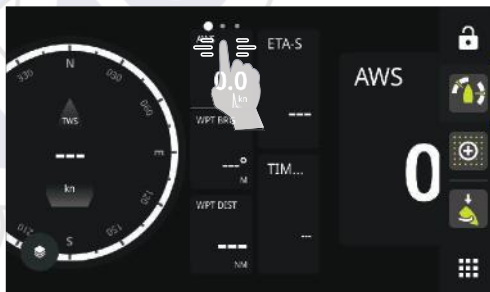

Editar y eliminar un panel de instrumentos

En la pantalla de inicio, mantenga pulsado el panel de instrumentos que desea editar o eliminar.

→ **Nota:** Es posible que algunas opciones no estén disponibles en función del panel de instrumentos seleccionado.

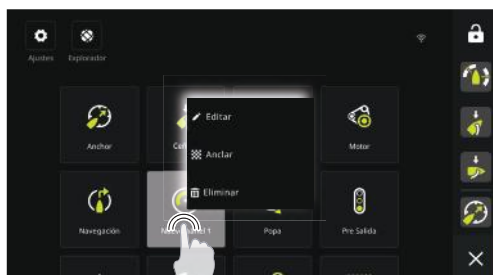

Personalizar la configuración del indicador

Los indicadores incluidos en un panel de instrumentos se pueden personalizar. Mantenga pulsado el indicador para mostrar las opciones de edición.

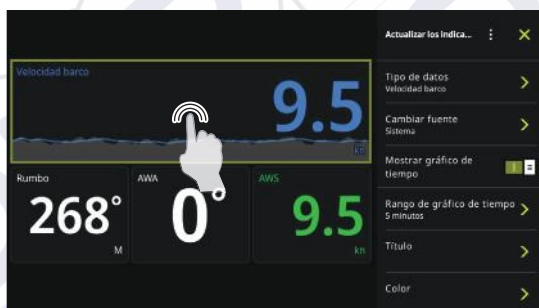

Crear un panel de instrumentos nuevo

→ **Nota:** Puede empezar desde cero un panel de instrumentos, desde una plantilla o desde un panel guardado. Un panel de instrumentos guardado es uno de los que ha creado con anterioridad.





- A** Cambie los ajustes del indicador, elija los datos que se mostrarán en él.
- B** Cambie el tamaño del indicador.
- C** Cambie los atributos del panel de instrumentos.

Ajustes del sistema

Acceda a los ajustes del sistema desde la pantalla de inicio.

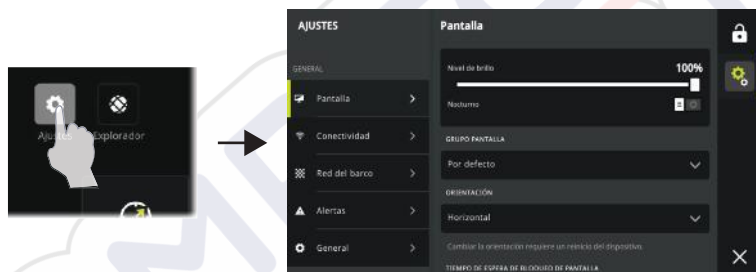

Menú de acceso rápido

Utilice el menú de acceso rápido para cambiar el brillo de la pantalla, activar el modo noche/día o informar de un problema.

Acceda al menú deslizando el dedo desde el borde superior de la pantalla.

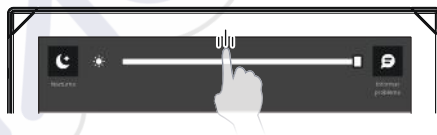

Manuales de productos

Para obtener la información más reciente y la documentación actualizada, consulte la página web:

www.bandg.com.

Tietoa tästä asiakirjasta

Tässä asiakirjassa kuvataan laitteen perustoiminnot.

Järjestelmän virran kytkeminen ja katkaiseminen

Järjestelmä kytkeytyy toimintaan, kun virta kytketään.

Ensimmäinen käynnistys

Kun käynnistät yksikön ensimmäisen kerran ja tehdasasetusten palauttamisen jälkeen, näyttöön avautuu ohjattu asetusten määrittystoiminto. Ohjattu määrittystoiminto opastaa näytön suunnan, kielen ja muiden asetusten valitsemisessa.

→ **Huomautus:** kaikkia ensiasennuksen aikana tehtyjä asetuksia voidaan muuttaa myöhemmin järjestelmäasetuksista.

Näytön lukitus / lukituksen avaus

Näyttö lukittuu oletusarvoisesti automaattisesti, kun laite on käyttämättömänä tietyn ajan. Tätä näytön lukitustoimintoa voi muuttaa järjestelmäasetuksissa.

Kun kojelauta-palkki on näkyvässä, lukitse näyttö painamalla lukituspainiketta.

Voit avata näytön lukituksen pyyhkäisemällä näytön oikeasta reunasta, jos näyttö on asennettu vaakasuunnassa. Jos näyttö on asennettu pystysuunnassa, pyyhkäise näytön alareunasta.

Vaakasuunta



Pysty-
suunta



Vaakasuunta



Pysty-
suunta



Aloituspäyttö

Aloituspäyttöön pääsee mistä tahansa toiminnosta painamalla Aloituspainiketta.

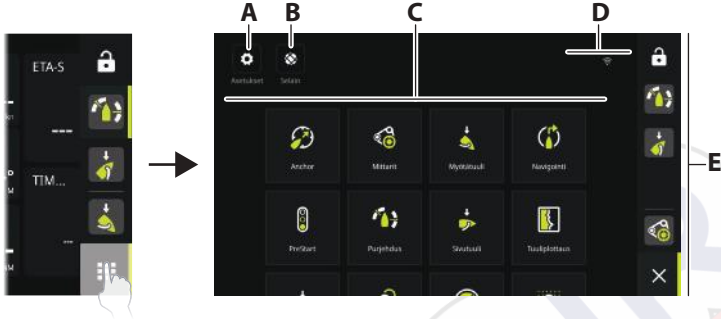

- A** Asetukset-painikkeella pääsee järjestelmäasetuksiin.
- B** Selainpainikkeella pääsee B&G® CPU -verkkopalvelimelle tai selaamaan verkkosivuja.
- C** Kojelaudat – valitse aktivoitava kojelauta tai luo mukautettu valitsemalla Uusi kojelauta.
- D** Tilapalkki
- E** Kojelauta-palkki – kiinnitettyt ja viimeksi käytetyt kojelaudat.

Kojelauta-palkki



- A** Lukituspainike
 - B** Kiinnitettyt kojelaudat – käyttäjän suosikkikojelaudat.
 - C** Viimeksi käytetty kojelauta.
 - D** Aloituspainike
- **Huomautus:** Aktiivinen kohde näkyy korostettuna kojelaudan palkissa.

Kojelaudan kiinnitys/irrotus

Kojelaudan kiinnittäminen

Paina aloitusnäytössä pitkään kojelautaa, jonka haluat kiinnittää kojelauta-palkkiin. Voit kiinnittää kojelaudan uuteen paikkaan tai korvata kojelaudan nykyisen sijainnin palkissa.



Kojelaudan kiinnityksen poistaminen

Paina pitkään kojelauta-palkkia, niin näet irrotus-vaihtoehdon.

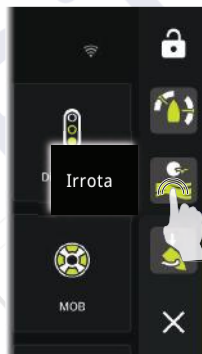

Kojelaudat

Vaihda kiinnitettyjen kojelautojen välillä pyyhkäisemällä vasemmalle tai oikealle.

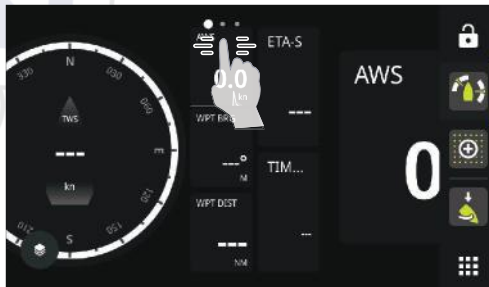

Kojelaudan muokkaaminen ja poistaminen

Paina aloitusnäytössä pitkään kojelautaa, jota haluat muokata tai jonka haluat poistaa.

→ **Huomautus:** Tietyt asetukset eivät ehkä ole käytettävissä kaikissa kojelauodoissa.



Mittarin asetusten mukauttaminen

Kojelaudaan sisältyviä mittareita voi mukauttaa. Tuo muokausasetukset näkyviin pitämällä mittari-painiketta painattuna.



Uuden kojelaudan luominen

→ **Huomautus:** Voit aloittaa tyhjästä kojelaudasta, mallista tai tallennetusta kojelaudasta. Tallennettu kojelauta on yksi aiemmin luomistasi kojelauodoista.

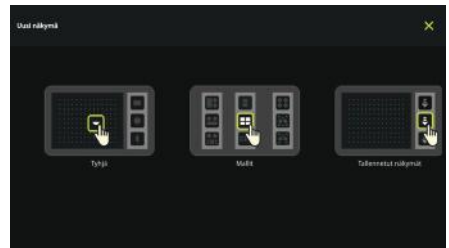



- A** Muuta mittarin asetuksia ja valitse mittarissa näytettävät tiedot.
- B** Muuta mittarin kokoa.
- C** Muuta kojelaudan ominaisuuksia.

Järjestelmäasetukset

Järjestelmäasetuksiin pääsee aloitusnäytöstä.

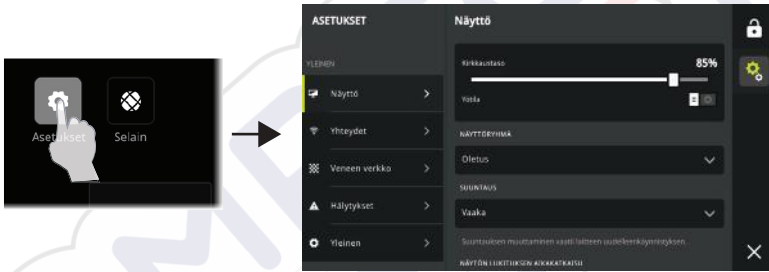

Pikavalikko

Pikavalikossa voit muuttaa näytön kirkkautta, ottaa yö-/päivätilan käyttöön tai ilmoittaa ongelmasta.

Avaa valikko pyyhkäisemällä näytön yläreunasta.

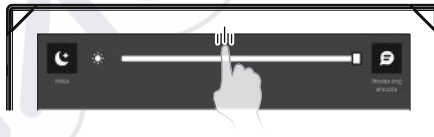

Tuotteiden käyttöoppaat

Uusimmat tiedot ja päivitettyt asiakirjat ovat osoitteessa www.bandg.com.

À propos de ce document

Ce document décrit le fonctionnement de base de l'appareil.

Mise en marche/arrêt du système

L'appareil s'allume lorsqu'il est mis sous tension.

Premier démarrage

Lors du premier démarrage de l'appareil ou après une réinitialisation aux réglages d'usine, l'appareil affiche un assistant d'installation. L'assistant vous guide lors de la configuration de l'orientation de l'écran, de la langue et d'autres paramètres.

→ **Remarque :** Tous les paramètres définis lors de la première configuration peuvent être modifiés ultérieurement à partir des paramètres système.

Verrouillage/déverrouillage de l'écran

Par défaut, l'écran est automatiquement verrouillé lorsque l'appareil est inactif pendant un certain temps. Cette fonction de verrouillage de l'écran peut être modifiée dans les paramètres système.

Lorsque la barre du tableau de bord s'affiche, appuyez sur le bouton de verrouillage pour verrouiller l'écran.

Si l'écran est installé en orientation paysage, faites glisser votre doigt depuis son bord droit pour le déverrouiller. S'il est installé en orientation portrait, faites glisser votre doigt depuis le bas de l'écran.

Orientation paysage



Orientation portrait



Orientation paysage



Orientation portrait



Écran d'accueil

Vous pouvez accéder à l'écran d'accueil en appuyant sur le bouton Accueil.

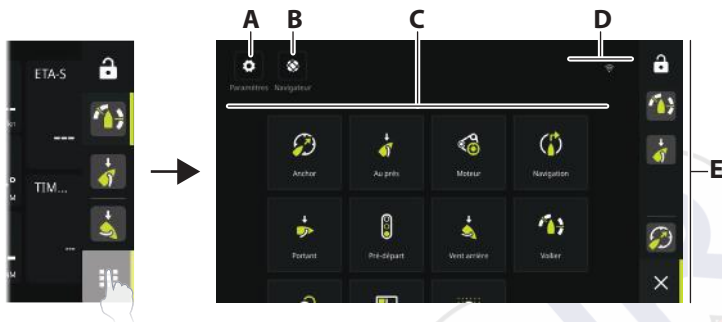

- A** Bouton Paramètres : permet d'accéder aux paramètres système.
- B** Bouton Navigateur : permet d'accéder au serveur Web de l'unité centrale B&G® ou de naviguer sur Internet.
- C** Tableaux de bord : sélectionnez le tableau de bord désiré pour l'activer, ou sélectionnez l'option Nouveau tableau de bord pour créer un tableau de bord personnalisé.
- D** Barre d'état
- E** Barre de tableau de bord : tableaux de bord épinglés et récemment utilisés.

Barre de tableau de bord

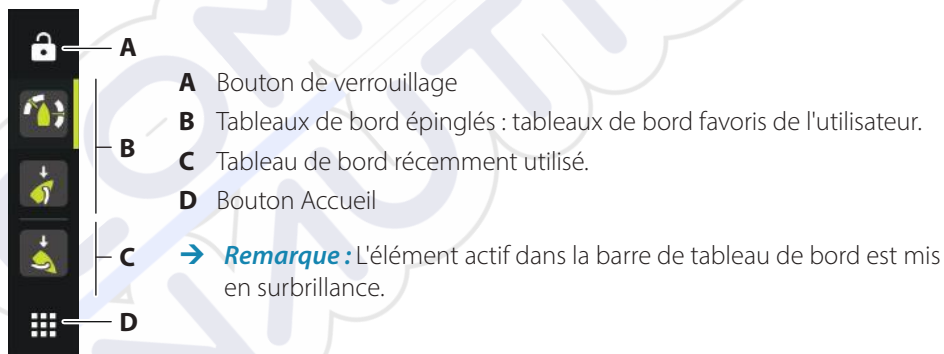

Épingler/détacher un tableau de bord

Épingler un tableau de bord

Sur l'écran d'accueil, appuyez longuement sur le tableau de bord que vous souhaitez épingler à la barre de tableau de bord. Il est possible d'épingler un tableau de bord dans une nouvelle position ou d'écraser la position existante sur la barre de tableau de bord.

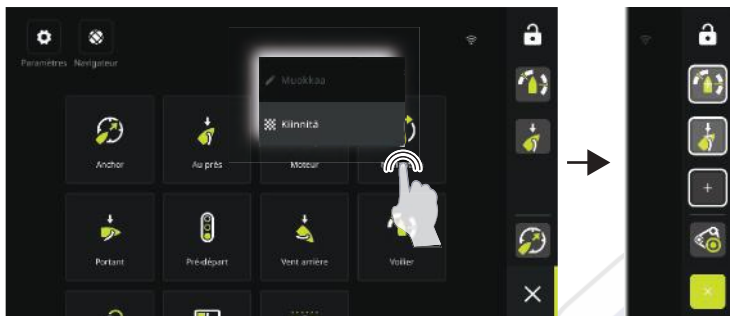

Détacher un tableau de bord

Dans la barre de tableau de bord, appuyez longuement sur le tableau de bord que vous souhaitez détacher pour afficher l'option Détacher.

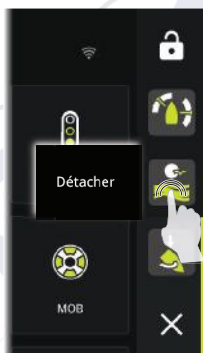

Tableaux de bord

Faites glisser votre doigt vers la gauche/droite pour naviguer entre les tableaux de bord épinglés.



Modifier et supprimer un tableau de bord

Sur l'écran d'accueil, appuyez longuement sur le tableau de bord que vous souhaitez modifier ou supprimer.

→ **Remarque :** Certaines options peuvent ne pas être disponibles selon le tableau de bord sélectionné.

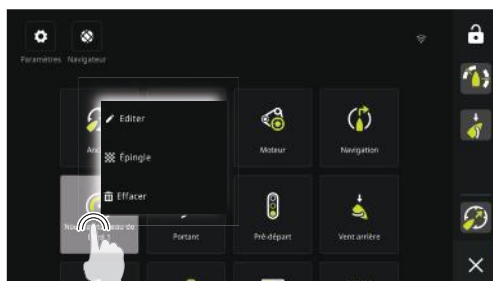

Personnaliser les paramètres de jauge

Les jauges incluses dans un tableau de bord sont personnalisables. Appuyez sur la jauge et maintenez-la enfoncée pour afficher les options d'édition.

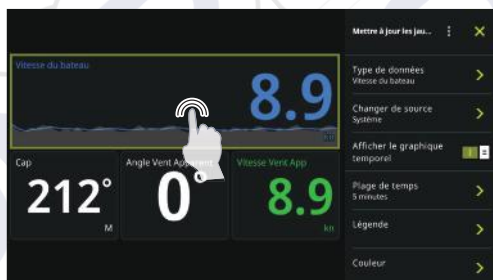

Créer un tableau de bord

→ **Remarque :** Il est possible de le créer à partir d'un tableau de bord vierge, d'un modèle ou d'un tableau de bord enregistré. Un tableau de bord enregistré est un tableau de bord créé précédemment.

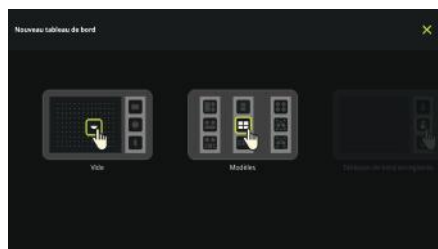
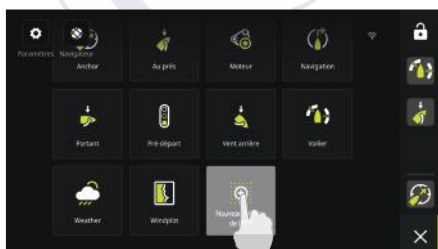



- A** Modifiez les paramètres de la jauge et choisissez les données à afficher sur la jauge.
- B** Redimensionnez la jauge.
- C** Modifiez les attributs du tableau de bord.

Paramètres système

Les paramètres système sont accessibles à partir de l'écran d'accueil.

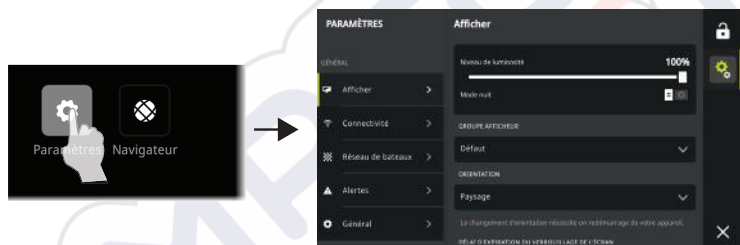

Menu d'accès rapide

Utilisez le menu d'accès rapide pour modifier la luminosité de l'écran, activer le mode nuit/jour ou signaler un problème.

Accédez au menu en faisant glisser votre doigt depuis le bord supérieur de l'écran.

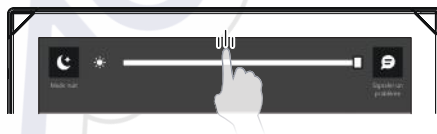

Manuels des produits

Pour obtenir les informations les plus récentes et la documentation actualisée, consultez le site Web :

www.bandg.com.

Informazioni su questo documento

Questo documento descrive il funzionamento di base dell'unità.

Accensione/spengimento del sistema

L'unità si accende quando viene applicata l'alimentazione.

Primo avvio

Quando l'unità viene avviata per la prima volta, o dopo un ripristino delle impostazioni di fabbrica, l'unità visualizza l'installazione guidata. La procedura guidata consente di configurare l'orientamento dello schermo, la lingua e altre impostazioni.

→ **Nota:** tutte le impostazioni effettuate durante la prima configurazione possono essere modificate in un secondo momento dalle impostazioni del sistema.

Blocco/sblocco dello schermo

Per impostazione predefinita, lo schermo viene bloccato automaticamente quando l'unità rimane inattiva per un determinato periodo di tempo. Questa funzione di blocco dello schermo può essere modificata nelle impostazioni del sistema.

Quando viene visualizzata la barra con i pannelli, premere il pulsante di blocco per bloccare lo schermo.

Per sbloccare lo schermo, se è installato con orientamento orizzontale, scorrere dal bordo destro dello schermo. Se installato con orientamento verticale, scorrere dalla parte inferiore del display.

Orientamento
orizzontale



Orientamento
verticale



Orientamento
orizzontale



Orientamento
verticale



Schermata iniziale

La schermata iniziale è accessibile da qualsiasi attività, semplicemente selezionando il tasto Home.

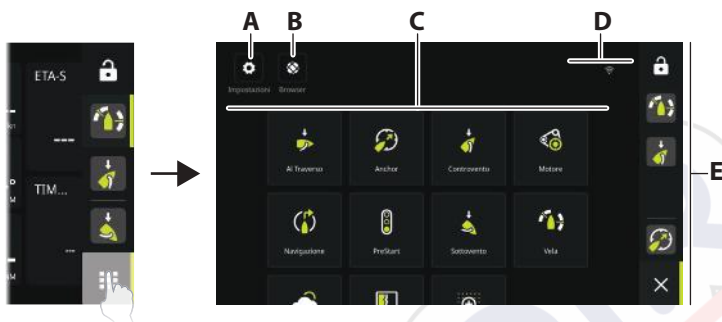

- A** Pulsante delle impostazioni: consente di accedere alle impostazioni del sistema.
- B** Pulsante di navigazione: può essere utilizzato per accedere al server Web B&G® CPU o per navigare in Internet.
- C** Pannelli: selezionare il pannello che si desidera attivare o l'opzione Nuovo pannello per creare un pannello personalizzato.
- D** Barra di stato
- E** Barra con i pannelli: pannelli bloccati e utilizzati di recente.

Barra con i pannelli

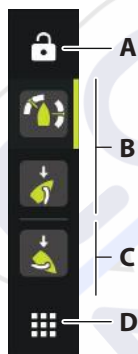

- A** Pulsante di blocco
 - B** Pannelli bloccati: pannelli preferiti dall'utente.
 - C** Pannelli utilizzati di recente.
 - D** Pulsante Pagina iniziale
- ➔ **Nota:** viene evidenziato l'elemento attivo nella barra dei pannelli.

Blocco/sblocco di un pannello

Blocco di un pannello

Nella schermata iniziale, tenere premuto il pannello che si desidera bloccare alla barra dei pannelli. È possibile bloccare un pannello in una nuova posizione o sovrascrivere la posizione esistente nella barra dei pannelli.

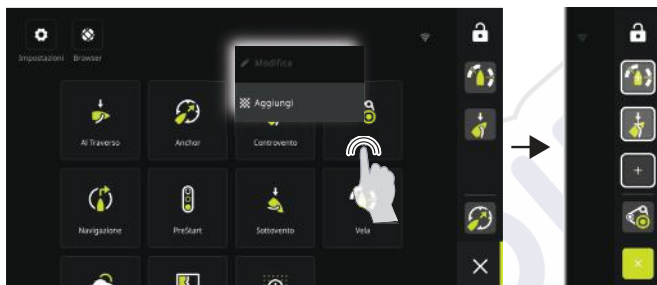

Sblocco di un pannello

Dalla barra dei pannelli, tenere premuto per visualizzare l'opzione di sblocco.

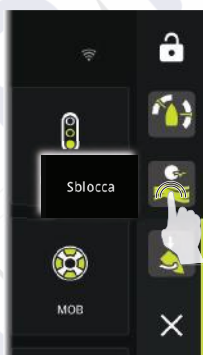

Pannelli

Scorrere verso sinistra/destra per passare da un pannello bloccato all'altro.



Modifica ed eliminazione di un pannello

Nella schermata iniziale, tenere premuto il pannello che si desidera modificare o eliminare.

→ **Nota:** alcune opzioni potrebbero non essere disponibili a seconda del pannello selezionato.

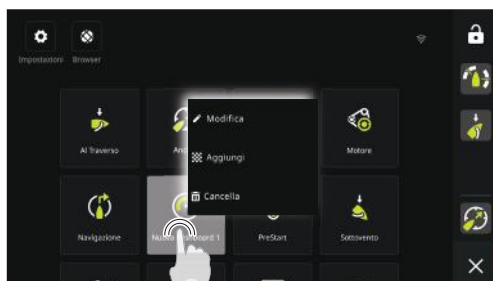

Personalizzazione delle impostazioni degli indicatori

È possibile personalizzare gli indicatori inclusi in un pannello. Tenere premuto l'indicatore per visualizzare le opzioni di modifica.



Creazione di un nuovo pannello

→ **Nota:** è possibile iniziare da un pannello vuoto, da un modello o da un pannello salvato. Un pannello salvato è uno dei pannelli creati in precedenza.

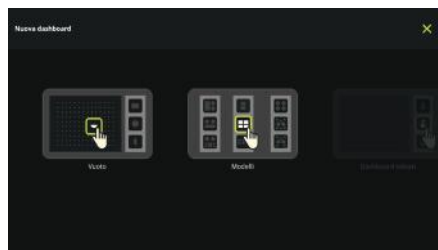
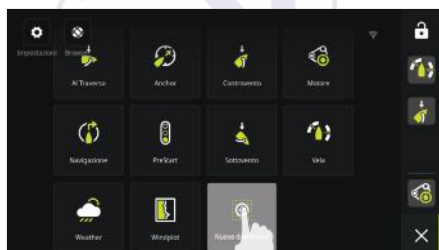



- A** Modificare le impostazioni degli indicatori, scegliere i dati da visualizzare sull'indicatore.
- B** Ridimensionare l'indicatore.
- C** Modificare gli attributi del pannello.

Impostazioni di sistema

È possibile accedere alle impostazioni di sistema dalla schermata iniziale.

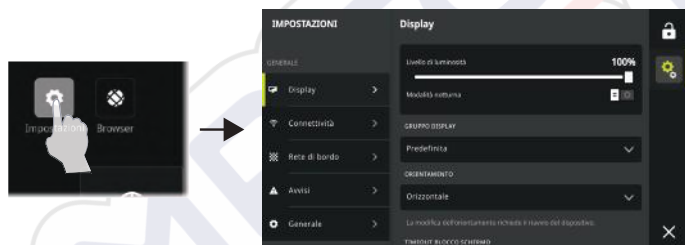

Menu di accesso rapido

Utilizzare il menu di accesso rapido per modificare la luminosità dello schermo, attivare la modalità notte/giorno o per segnalare un problema.

Accedere al menu scorrendo dal bordo superiore del display.

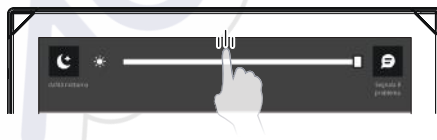

Manuali dei prodotti

Per le informazioni più recenti e la documentazione aggiornata, fare riferimento al sito Web: www.bandg.com.

Over dit document

In dit document wordt de basisbediening van het apparaat beschreven.

Het systeem IN- en UITSCHAKELEN

Het apparaat wordt INGESCHAKELD wanneer de voeding wordt ingeschakeld.

Voor de eerste keer opstarten

Wanneer het apparaat voor de eerste keer wordt opgestart of na een herstel van de waarden naar de fabrieksinstellingen, wordt een installatiewizard weergegeven. De wizard begeleidt u bij het instellen van de schermoriëntatie, taal en andere instellingen.

→ **Opmerking:** Alle instellingen die u voor het eerst hebt ingesteld, kunt u later wijzigen via de systeeminstellingen.

Het scherm vergrendelen/ontgrendelen

Standaard wordt het scherm automatisch vergrendeld wanneer het apparaat een bepaalde tijd niet wordt gebruikt. Deze schermvergrendelingsfunctie kan worden gewijzigd in de systeeminstellingen.

Wanneer de dashboardbalk wordt weergegeven, drukt u op de vergrendelingsknop om het scherm te vergrendelen.

Veeg vanaf de rechterrand van het scherm om het scherm te ontgrendelen als het scherm in de stand Liggend is geïnstalleerd. Veeg vanaf de onderkant van het scherm als het scherm in de stand Staand is geïnstalleerd.

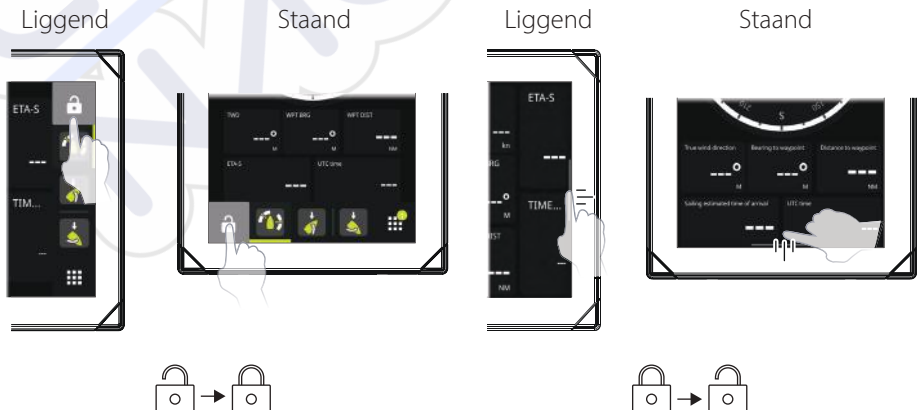

Home scherm

Het Home scherm is op elk moment toegankelijk door de knop Home te selecteren.

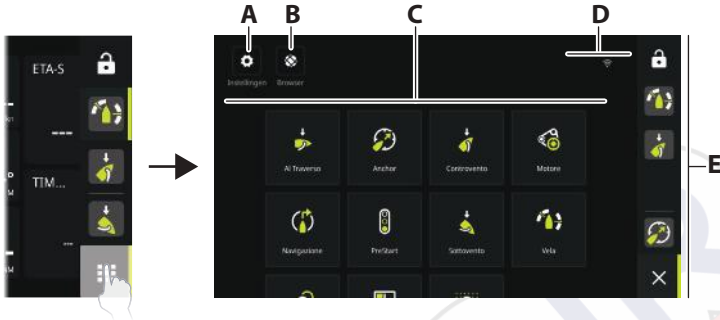

- A** Knop Instellingen - geeft toegang tot de systeeminstellingen.
- B** Browserknop - kan worden gebruikt om de B&G® CPU-webserver te openen of om op internet te surfen.
- C** Dashboards - selecteer het dashboard dat u wilt activeren of selecteer de nieuwe dashboardoptie om een aangepast dashboard te maken.
- D** Statusbalk
- E** Dashboardbalk - vastgemaakte en onlangs gebruikte dashboards.

Dashboardbalk



- A** Vergrendelingsknop
 - B** Vastgezette dashboards - favoriete dashboards van gebruikers.
 - C** Onlangs gebruikt dashboard.
 - D** Home knop
- **Opmerking:** Het actieve item in de dashboardbalk wordt gemarkeerd.

Een dashboard vastmaken/losmaken

Een dashboard vastmaken

Houd in het beginscherm ingedrukt op het dashboard dat u aan de dashboardbalk wilt vastmaken. U kunt een dashboard vastmaken aan een nieuwe positie of bestaande positie op de dashboardbalk overschrijven.

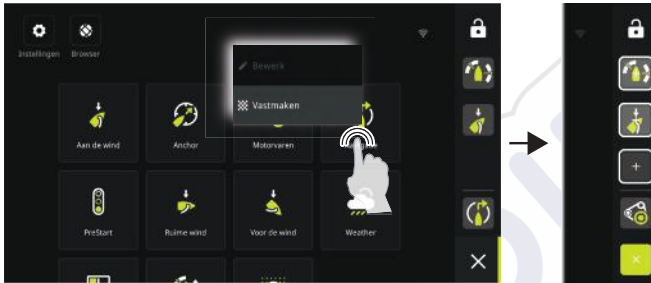

Een dashboard losmaken

Houd op de dashboardbalk ingedrukt om de optie voor losmaken weer te geven.



Dashboards

Veeg naar links/rechts om te schakelen tussen vastgezette dashboards.



Een dashboard bewerken en verwijderen

Houd in het beginscherm ingedrukt op het dashboard dat wilt bewerken of verwijderen.

→ **Opmerking:** Sommige opties zijn mogelijk niet beschikbaar, afhankelijk van het geselecteerde dashboard.



De meterinstellingen aanpassen

Meters in een dashboard kunnen worden aangepast. Houd op de meter ingedrukt om de bewerkingsopties weer te geven.

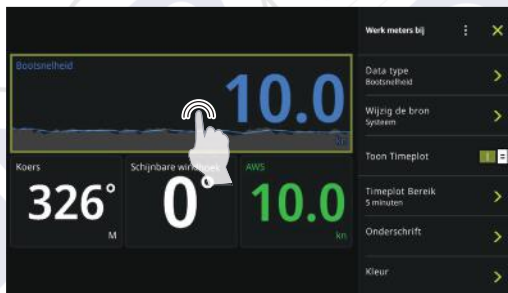

Een nieuw dashboard maken.

→ **Opmerking:** U kunt beginnen vanaf een leeg dashboard, een sjabloon of een opgeslagen dashboard. Een opgeslagen dashboard is een van de vorige dashboards die u hebt gemaakt.

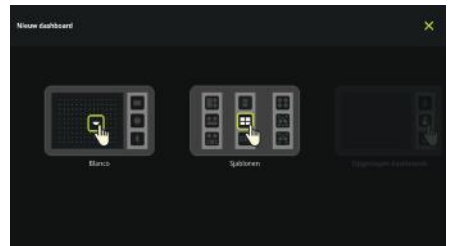
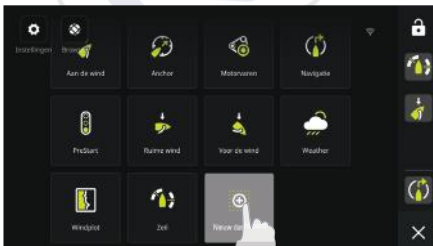



- A** Wijzig de meterinstellingen, kies de gegevens die op de meter moeten worden weergegeven.
- B** Wijzig het formaat van de meter.
- C** Wijzig de dashboardkenmerken.

Systeminstellingen

De systeeminstellingen zijn toegankelijk vanaf het beginscherm.

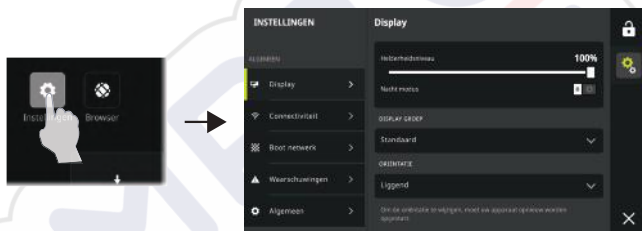

Snelmenu

Gebruik het Snelmenu om de helderheid van het scherm te wijzigen, de nacht-/dagmodus te activeren of een probleem te melden.

Open het menu door vanaf de bovenrand van het scherm te vegen.

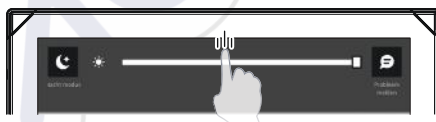

Handleidingen

Voor de meest recente informatie en bijgewerkte documentatie raadpleegt u de website: www.bandg.com.

Om dette dokumentet

Dette dokumentet beskriver grunnleggende bruk av enheten.

Slå systemet PÅ/AV

Enheden vil bli slått PÅ når strømmen tilføres.

Oppstart første gang

Når enheten startes for første gang eller etter tilbakestilling til fabrikkinnstillingene, viser enheten en konfigurasjonsveiviser. Konfigurasjonsveiviseren veileder deg gjennom skjermoppsettet, språk og andre innstillinger.

→ **Merk:** Eventuelle innstillinger som ble gjort første gang systemet ble satt opp, kan endres senere fra systeminnstillingene.

Låse / låse opp skjermen

Standardinnstillingen låser skjermen automatisk når enheten har vært inaktiv en stund. Denne skjermlåsfunksjonen kan endres i systeminnstillingene.

Når instrumentbordet vises, trykker du på låseknappen for å låse skjermen.

Hvis du vil låse opp skjermen i liggende stilling, sveiper du fra høyre kant av skjermen. Hvis du vil låse opp skjermen i stående stilling, sveiper du fra bunnen av skjermen.

Liggende stilling



Stående stilling



Liggende stilling



Stående stilling



Hjem-skjerm

Du kan åpne Hjem-skjermvinduet ved å velge Hjem-knappen.

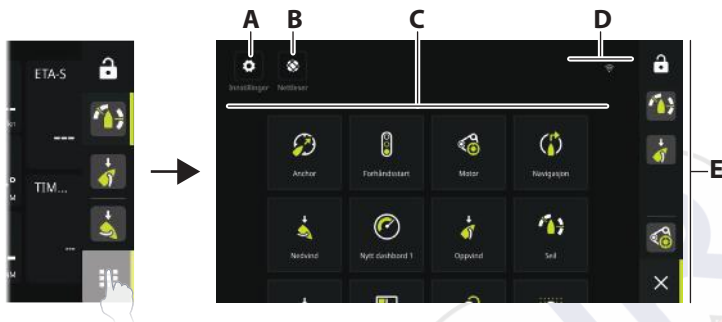

- A** Innstillingsknapp – gir tilgang til systeminnstillingene.
- B** Nettleserknapp – kan brukes til å få tilgang til B&G® CPU-nettserveren eller til å surfe på internett.
- C** Instrumentbord – velg instrumentbordet du vil aktivere, eller velg det nye instrumentbord-alternativet for å opprette et egendefinert instrumentbord.
- D** Statuslinje
- E** Instrumentbord – festede og nylig brukte instrumentbord.

Instrumentbord

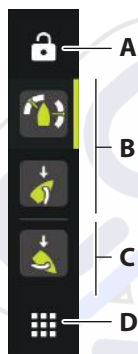

- A** Låseknapp
 - B** Festede instrumentbord – favorittinstrumentbord for brukere.
 - C** Nylig brukt instrumentbord.
 - D** Hjem-knapp
- **Merk:** Det aktive elementet i instrumentpanelet vil bli markert.

Fest / løsne et instrumentbord

Fest et instrumentbord

På hjem-skjermen trykker du på og holder nede instrumentpanelet som du vil feste til instrumentpanelets bar. Du kan feste et instrumentbord til en ny posisjon eller overskrive eksisterende posisjoner på instrumentbordet.

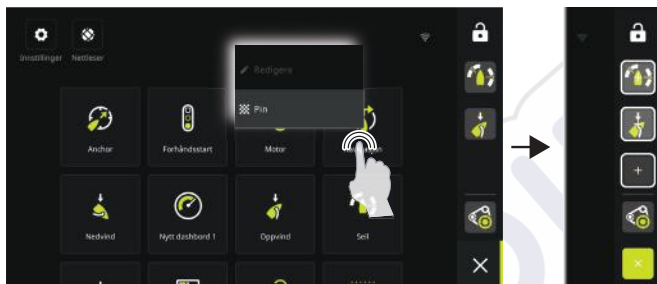

Løsne et instrumentbord

Trykk på og hold nede på instrumentbordet for å vise alternativet for å løsne.

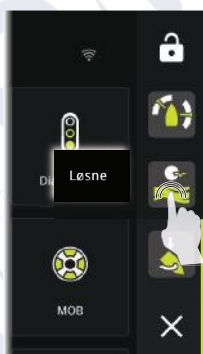

Instrumentpaneler

Skyv til venstre /høyre for å veksle mellom festede instrumentbord.



Rediger og slett et instrumentbord

Trykk på og hold nede på instrumentbordet du vil redigere eller slette, på hjem-skjermen.

→ **Merk:** Noen alternativer er kanskje ikke tilgjengelige, avhengig av det valgte instrumentbordet.

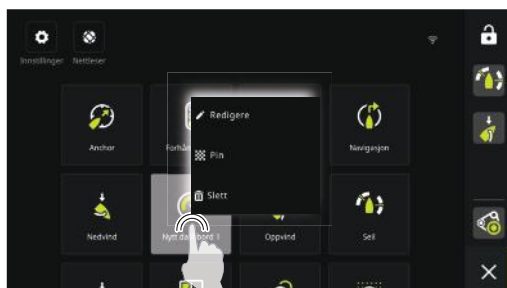

Tilpass målerinnstillingene

Målere som er inkludert i et instrumentbord, kan tilpasses. Trykk på og hold nede måleren for å vise redigeringsalternativene.



Opprett et nytt instrumentbord

→ **Merk:** Du kan starte fra et tomt instrumentbord, en mal eller fra et lagret instrumentbord. Et lagret instrumentbord er et av de tidligere instrumentbordene du har opprettet.

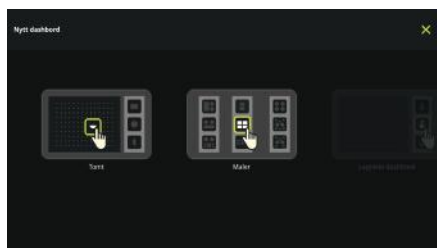
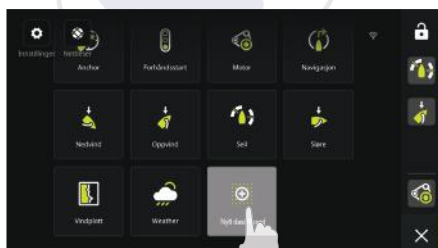



- A** Endre målerinnstillinger, og velg data som skal vises på måleren.
- B** Endring av størrelse på måler.
- C** Endre egenskapene til instrumentbordet.

Systeminnstillinger

Du får tilgang til systeminnstillingene fra hjem-skjermen.



Knapper for hurtigtilgang

Bruk menyen for hurtigtilgang til å endre lysstyrken på skjermen, aktivere natt- /dagmodus eller for å rapportere et problem.

Åpne menyen ved å sveipe fra øverst på skjermen.

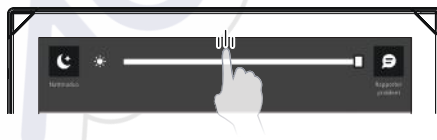

Produkt håndbøker

Hvis du vil ha den nyeste informasjonen og oppdatert dokumentasjon, kan du gå til nettstedet:

www.bandg.com

Acerca deste documento

Este documento descreve o funcionamento básico da unidade.

Ligar e desligar o sistema

A unidade ligar-se-á quando a alimentação for aplicada.

Primeira utilização

Quando a unidade é iniciada pela primeira vez ou após a reposição de fábrica, a unidade apresenta um assistente de configuração. O assistente irá guiá-lo ao longo da configuração da orientação do ecrã, idioma e outras definições.

→ **Nota:** Quaisquer definições aplicadas durante a primeira configuração podem ser alteradas posteriormente a partir das definições do sistema.

Bloquear/desbloquear o ecrã

Por predefinição, o ecrã é automaticamente bloqueado quando a unidade se encontra inativa durante algum tempo. Esta funcionalidade de bloqueio do ecrã pode ser alterada nas definições do sistema.

Quando a barra do painel for apresentada, prima o botão de bloqueio para bloquear o ecrã.

Para desbloquear o ecrã, se tiver sido instalado na orientação horizontal, deslize o dedo a partir da extremidade direita do ecrã. Se tiver sido instalado na orientação vertical, deslize o dedo a partir da parte inferior do ecrã.

Orientação horizontal



Orientação vertical



Orientação horizontal



Orientação vertical



Ecrã inicial

O ecrã inicial é acedido através da seleção do botão Início.

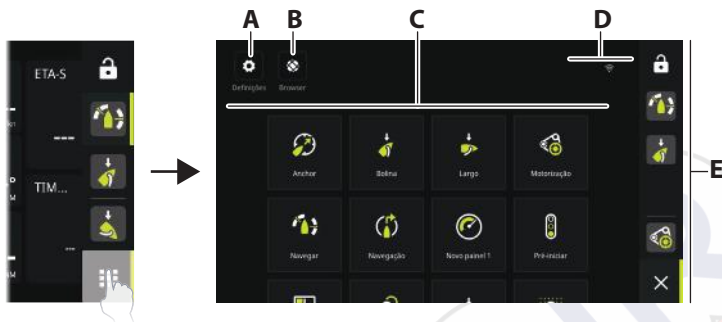

- A** Botão de definições – permite aceder às definições do sistema.
- B** Botão do navegador – pode ser utilizado para aceder ao servidor Web da CPU da B&G® ou para navegar na Internet.
- C** Painéis - seleccione o painel que pretende ativar ou seleccione a nova opção de painel para criar um painel personalizado.
- D** Barra de estado
- E** Barra do painel - painéis fixados e utilizados recentemente.

Barra do painel



- A** Botão de bloqueio
 - B** Painéis fixados - painéis favoritos do utilizador.
 - C** Painel utilizado recentemente.
 - D** Botão Início
- **Nota:** O item ativo na barra do painel será destacado.

Fixar/remover um painel

Fixar um painel

No ecrã inicial, mantenha premido o painel que pretende fixar à barra do painel. Pode fixar o painel numa nova posição ou substituir outro item na barra do painel.



Remover um painel

A partir da barra do painel, mantenha premido o painel que pretende remover até ser apresentada essa opção.

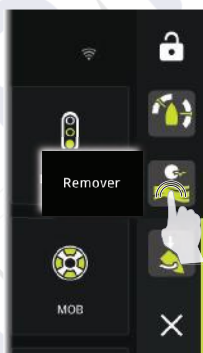

Painéis de informação

Deslize para a esquerda/direita para alternar entre painéis fixados.



Editar e eliminar um painel

No ecrã inicial, mantenha premido o painel que pretende editar ou eliminar.

→ **Nota:** Algumas opções podem não estar disponíveis dependendo do painel selecionado.

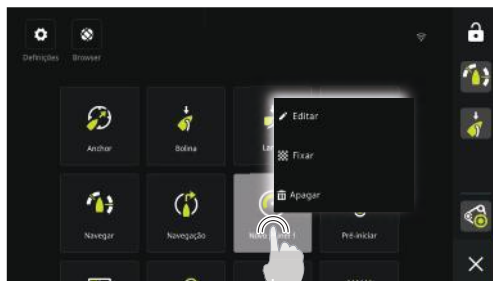

Personalizar as definições do indicador

Os indicadores incluídos num painel podem ser personalizados. Mantenha premido o indicador até as opções de edição serem apresentadas.



Criar um novo painel

→ **Nota:** Pode começar a partir de um painel vazio, de um modelo ou de um painel guardado. Um painel guardado é um dos painéis que criou anteriormente.

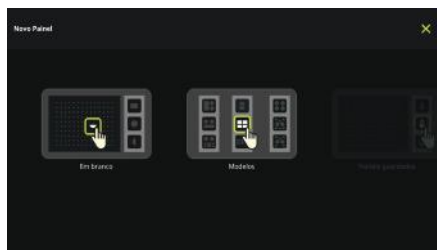
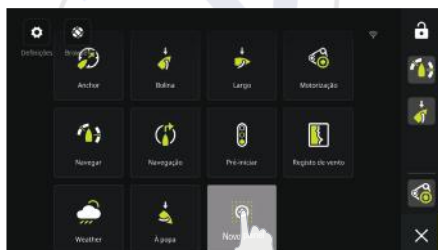



- A** Altere as definições do indicador e escolha os dados a serem apresentados no indicador.
- B** Indicador de redimensionamento.
- C** Altere os atributos do painel.

Definições de sistema

As definições do sistema são acessíveis a partir do ecrã inicial.

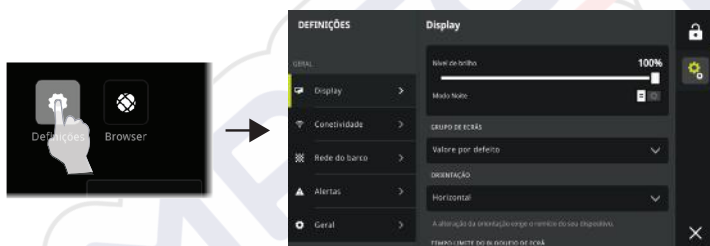

Menu de acesso rápido

Utilize o menu de acesso rápido para alterar o brilho do ecrã, ativar o modo noturno/diurno ou comunicar um problema.

Aceda ao menu deslizando o dedo a partir da extremidade superior do ecrã.

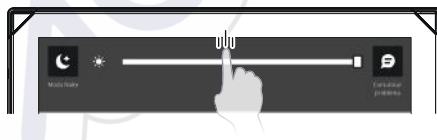

Manuais de produto

Para obter as informações mais recentes e a documentação atualizada, consulte o website: www.bandg.com.

Om det här dokumentet

I det här dokumentet beskrivs enhetens grundläggande funktion.

Slå PÅ och AV systemet

Enheten slås PÅ när strömmen slås till.

Första gången du startar enheten

När du startar enheten för första gången, samt efter en fabriksåterställning, visar enheten en installationsguide. Guiden vägleder dig genom inställningen av skärmorientering, språk och andra inställningar.

→ **Obs!** Alla inställningar som görs under den första installationen kan ändras senare via systeminställningarna.

Låsa/låsa upp skärmen

Som standard låses skärmen automatiskt när enheten är i viloläge under en tidsperiod. Den här skärmlåsfunktionen kan ändras i systeminställningarna.

När instrumentpanelfältet visas trycker du på låsknappen för att låsa skärmen.

Om du vill låsa upp skärmen drar du från skärmens högra kant om den är installerad i liggande riktning. Dra med fingret från skärmens nederkant om det är installerat i stående läge.

Liggande orientering



Stående orientering



Liggande orientering



Stående orientering



Startskärmen

Du öppnar startskärmen genom att välja hemknappen.

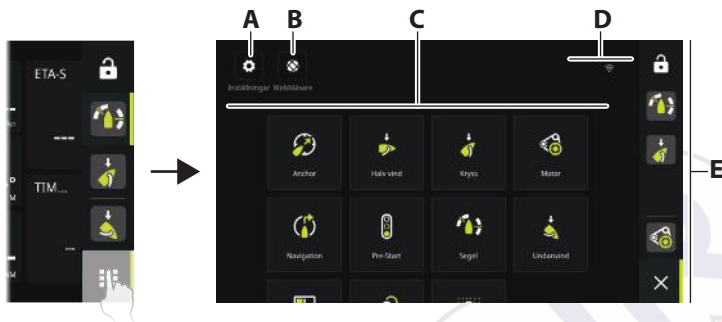

- A** Knappen Inställningar – ger åtkomst till systeminställningarna.
- B** Knappen Webbläsare – kan användas för att få åtkomst till B&G® CPU-webbservern eller för att surfa på internet.
- C** Instrumentpaneler – välj den instrumentpanel du vill aktivera eller välj det alternativet för ny instrumentpanel för att skapa en anpassad instrumentpanel.
- D** Statusfält
- E** Instrumentpanelfält – fästa och nyligen använda instrumentpaneler.

Instrumentpanelfält



- A** Låsknapp
 - B** Fästa instrumentpaneler – användarens favoritinstrumentpaneler.
 - C** Senast använda instrumentpanel.
 - D** Hemknapp
- **Obs!** Det aktiva objektet i instrumentpanelfältet är markerat.

Fästa/ta bort en instrumentpanel

Fästa en instrumentpanel

På startskärmen trycker du på och håller ned den instrumentpanel som du vill fästa i instrumentpanelfälten. Du kan fästa en instrumentpanel på en ny position eller skriva över en befintlig position på instrumentpanelfälten.

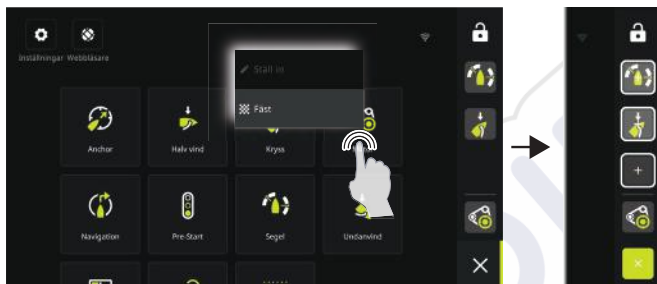

Ta bort en instrumentpanel

Tryck ned och håll kvar på instrumentpanelfälten för att visa borttagningsalternativet.

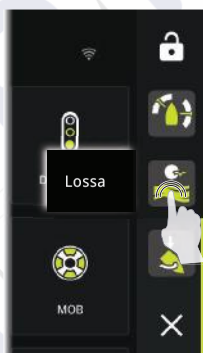

Instrumentpaneler

Dra åt vänster/höger för att växla mellan fästa instrumentpaneler.



Redigera och ta bort en instrumentpanel

På startskärmen trycker du på och håller ned den instrumentpanel som du vill redigera eller ta bort.

→ **Obs!** Vissa alternativ kanske inte är tillgängliga beroende på vald instrumentpanel.

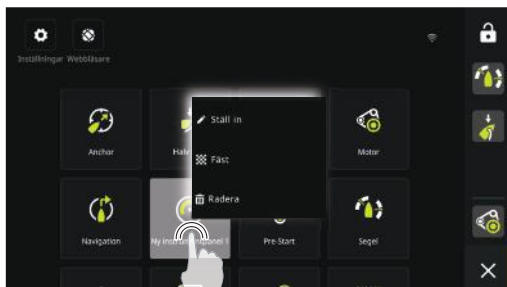

Anpassa mätarinställningar

Mätarna som finns på instrumentpanelen kan anpassas. Tryck på och håll ned mätaren så visas redigeringsalternativen.

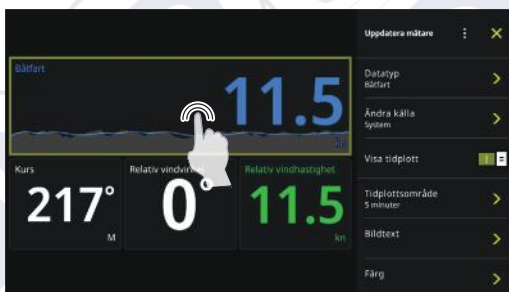

Skapa en ny instrumentpanel

→ **Obs!** Du kan starta från en tom instrumentpanel, en mall eller från en sparad instrumentpanel. En sparad instrumentpanel är en av dina tidigare instrumentpaneler som du har skapat.

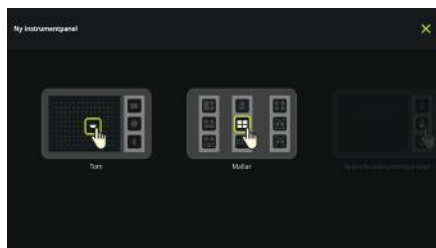
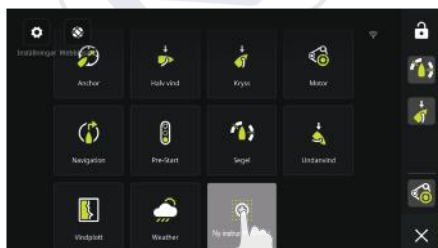



- A** Ändra mätarinställningar, välj data som ska visas på mätaren.
- B** Ändra storlek på mätaren.
- C** Byt panelattribut.

Systeminställningar

Systeminställningarna nås från startskärmen.

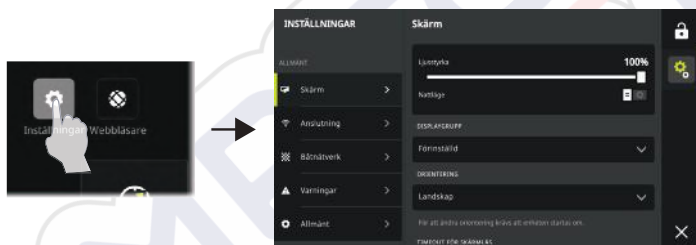

Snabbmeny

Använd snabbmenyn för att ändra skärmens ljusstyrka, aktivera natt-/dagläge eller för att rapportera ett problem.

Öppna menyn genom att dra med fingret från skärmens övre kant.

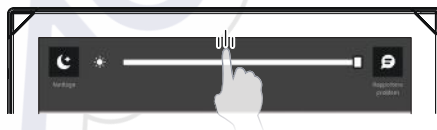

Produktmanualer

Den senaste informationen och den uppdaterade dokumentationen finns på webbplatsen: www.bandg.com.

关于本文档

本文档介绍了该装置的基本操作。

打开/关闭系统

当接通电源时，本装置将打开。

首次启动

首次启动装置时或在恢复出厂设置后，装置将会显示设置向导。此向导将引导您完成屏幕方向、语言的设置和其他设置。

→ **注意：**首次设置期间进行的任何设置都可以在以后从系统设置中更改。

锁定/解锁屏幕

默认情况下，当设备闲置一段时间后，屏幕会自动锁定。屏幕锁定功能可在系统设置中更改。

显示仪表盘栏时，按下锁定按钮可锁定屏幕。

要解锁屏幕，如果是横向安装，请从显示屏的右边边缘滑动。如果是纵向安装，请从显示屏底部滑动。



主屏幕

选择“主屏幕”按钮可访问主屏幕。

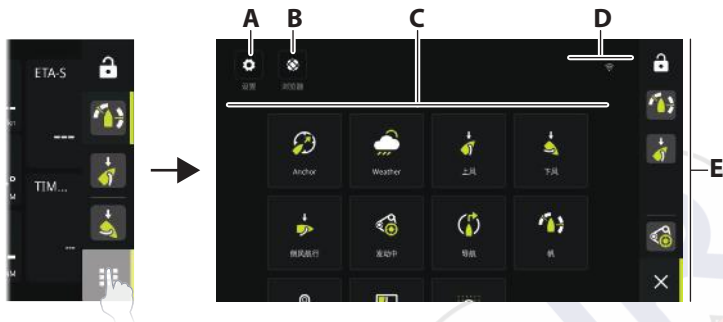

- A 设置按钮 - 可用于访问系统设置。
- B 浏览器按钮 - 可用于访问 B&G® CPU 网络服务器或浏览互联网。
- C 仪表盘 - 选择要激活的仪表盘, 或选择新仪表盘选项以创建自定义仪表盘。
- D 状态栏
- E 仪表盘栏 - 固定的和最近使用的仪表盘。

仪表盘栏



- A 锁定按钮
 - B 固定的仪表盘 - 用户收藏的仪表盘。
 - C 最近使用的仪表盘。
 - D “主屏幕”按钮
- ➔ 注意：仪表盘栏中的活动项目将突出显示。

固定/取消固定仪表盘

固定仪表盘

在主屏幕上，按住要固定到仪表盘栏的仪表盘。您可以将仪表盘固定到新位置或覆盖仪表盘栏上现有的位置。



取消固定仪表盘

在仪表盘栏中，按住可显示取消固定选项。



仪表盘

向左/向右滑动可在固定的仪表盘之间进行更改。

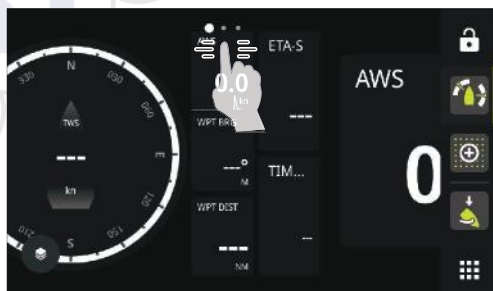

编辑和删除仪表盘

在主屏幕上，按住要编辑或删除的仪表盘。

→ **注意：**某些选项可能不可用，具体取决于所选的仪表盘。



自定义仪表设置

仪表盘中包含的仪表可以自定义。按住仪表以显示编辑选项。



创建新的仪表盘

→ **注意：**您可以从空白仪表盘、模板或从已保存的仪表盘开始。保存的仪表盘是您之前创建的某一个仪表盘。





- A 更改仪表设置，选择要在仪表上显示的数据。
- B 调整仪表的大小。
- C 更改仪表盘的属性。

系统设置

可从主屏幕访问系统设置。



快速访问菜单

使用快速访问菜单更改屏幕亮度、激活夜间/白天模式或报告问题。
从显示屏顶部边缘向下滑动以访问此菜单。

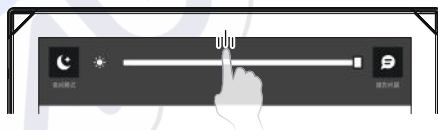

产品手册

有关最新信息和更新的文档，请参阅网站：
www.bandg.com。



©Reg. U.S. Pat. & Tm. Off. and ™ common law marks.
Visit www.navico.com/intellectual-property to review the global trademark rights and accreditations for Navico Holding AS and other entities.

www.bandg.com

About this document

This document describes the basic operation of the unit.

Turning the system ON/OFF

The unit will turn ON when power is applied.

First time startup

When you start the unit for the first time or after a factory reset, the unit displays a setup wizard. The wizard will guide you through the set up of the screen orientation, language, and other settings.

→ **Note:** Any settings made during the first time set up can be changed later from the system settings.

Lock/unlock the screen

By default, the screen is automatically locked when the unit is idle for a period of time. This screen lock feature can be changed in the system settings.

When the dashboard bar is shown, press the lock button to lock the screen.

To unlock the screen, if installed in landscape orientation swipe from the right edge of the display. If installed in portrait orientation swipe from the bottom of the display.

Landscape orientation



Portrait orientation



Landscape orientation



Portrait orientation

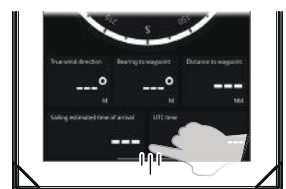

Home screen

The Home screen is accessed by selecting the Home button.

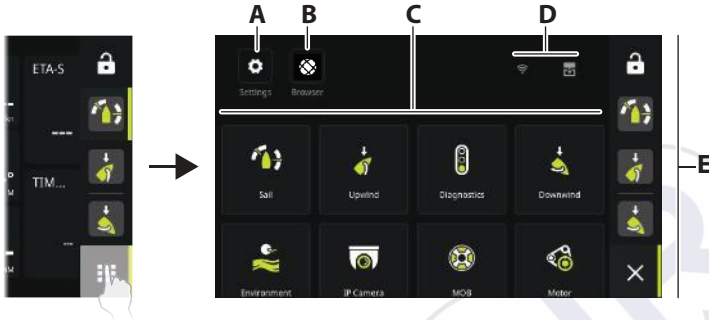

- A** Settings button - gives access to the system settings.
- B** Browser button - can be used to access the B&G® CPU web server or for browsing the internet.
- C** Dashboards - select the dashboard that you want to activate, or select the new dashboard option to create a custom dashboard.
- D** Status bar
- E** Dashboard bar - pinned and recently used dashboards.

Dashboard bar



- A** Lock button
 - B** Pinned dashboards - user favorite dashboards.
 - C** Recently used dashboard.
 - D** Home button
- **Note:** The active item in the dashboard bar will be highlighted.

Pin/unpin a dashboard

Pin a dashboard

On the home screen, press and hold on the dashboard that you want to pin to the dashboard bar. You can pin a dashboard to a new position or overwrite existing position on the dashboard bar.

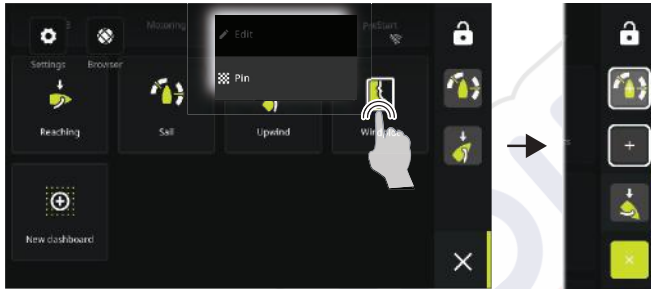

Unpin a dashboard

From the dashboard bar, press and hold to display the unpin option.



Dashboards

Swipe left/right to change between pinned dashboards.



Edit and delete a dashboard

On the home screen, press and hold on the dashboard you want to edit or delete.

→ **Note:** Some options might not be available depending on the selected dashboard.



Customize gauge settings

Gauges included in a dashboard can be customized. Press and hold on the gauge to display the edit options.



Create a new dashboard

→ **Note:** You can start from a blank dashboard, a template, or from a saved dashboard. A saved dashboard is one of your previous dashboards you have created.





- A** Change gauge settings, choose data to be shown on the gauge.
- B** Resize gauge.
- C** Change dashboard attributes.

System settings

The system settings is accessed from the home screen.

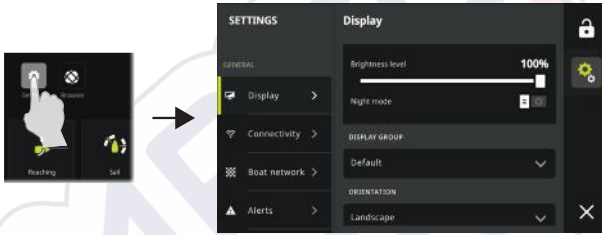

Quick access menu

Use the Quick access menu to change the screen brightness, activate night/day mode, or to report an issue.

Access the menu by swiping from the top edge of the display.

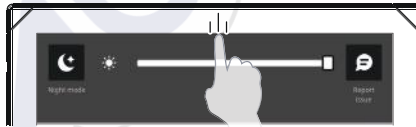

Product manuals

For the latest information and updated documentation refer to the website: www.bandg.com.



Technical specification

	9" unit	12" unit
Display		
Resolution	1280x720	1280x800
Brightness	1300 nits	1500 nits
Touch screen	Full touch screen (multi-touch)	
Viewing angles	80° top/bottom, 80° left/right	
Electrical		
Supply voltage	12/24 V DC (10 - 31.2 V DC min - max)	
Power consumption - Max	13 W	19 W
Recommended fuse rating (12 V / 24 V)	1.5 A	2 A
Environmental		
Temperature range	-15°C to 55°C (5°F to 131°F)	
Storage temperature	-20°C to 60°C (4°F to 140°F)	
Waterproof rating	IPX 6 and 7	
Interface/Connectivity		
Power/Ethernet	1x 8 pin power connector	
NMEA 2000®	1x Micro-C connector (network load 1 LEN)	
WIFI	802.11b/g/n	
Physical		
Compass Safe Distance - Metric, imperial	0.5 m (1.6 ft)	
Weight (display only)	1 kg (2.2 lbs)	2 kg (4.4 lbs)
Mounting type	Panel and rear mounting Rear mounting templates are available on www.bandg.com	

Dimensional drawing

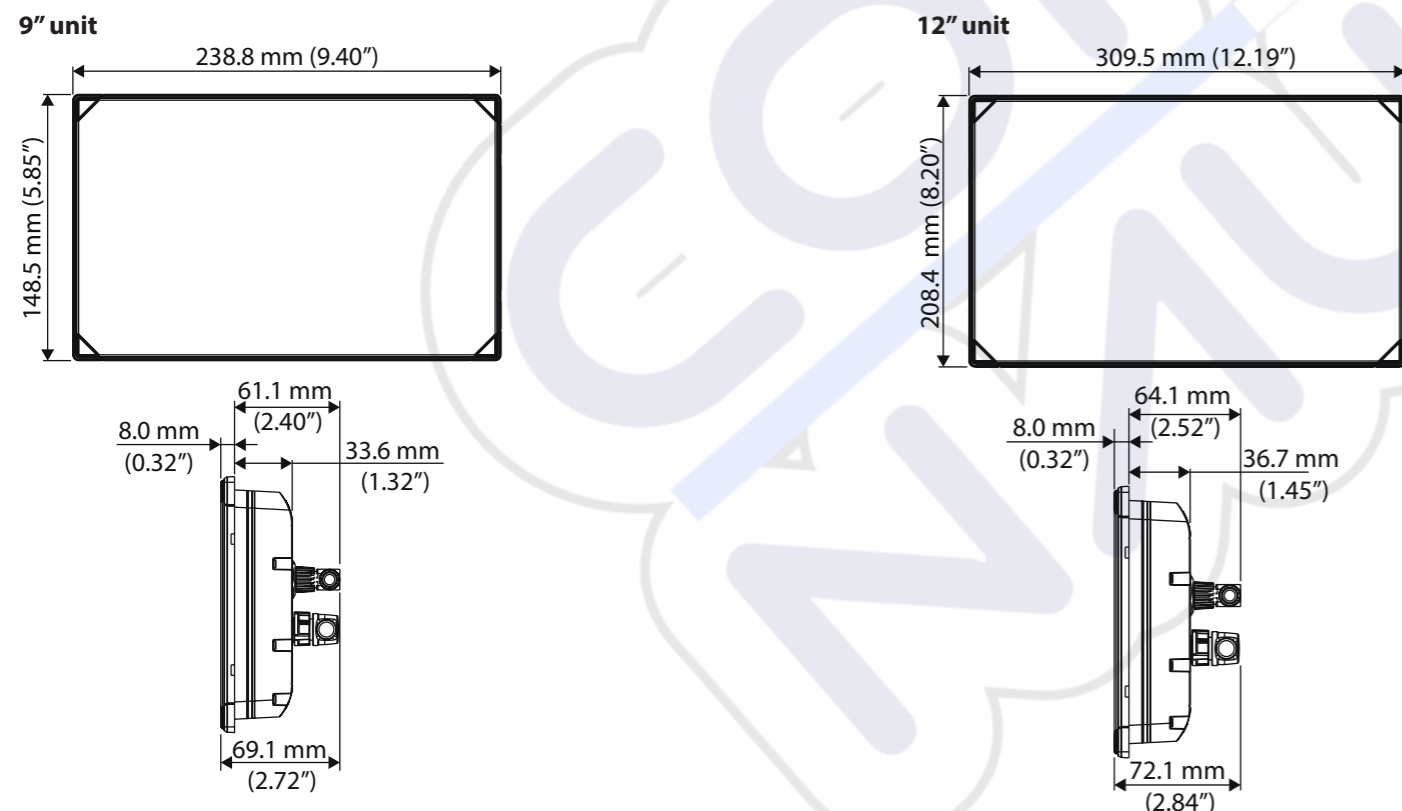

B&G®

NEMESIS™ DISPLAY INSTALLATION GUIDE

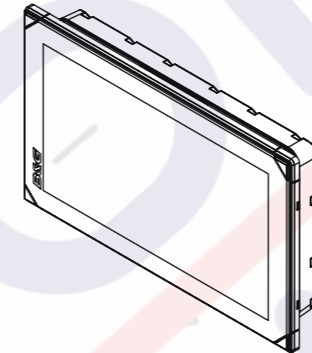

Parts included

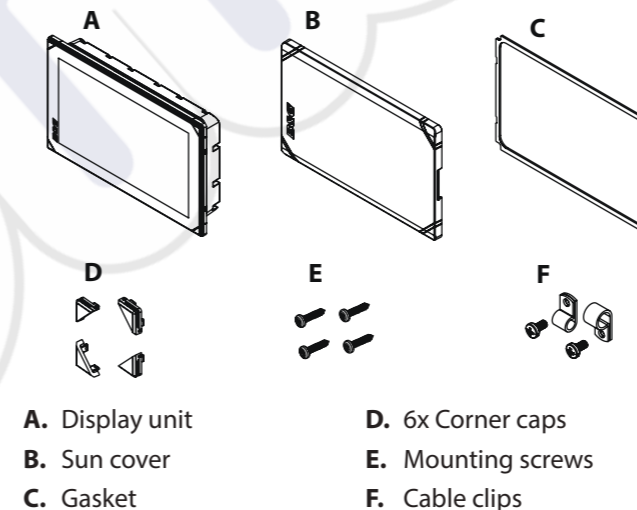

Accessories (sold separately)

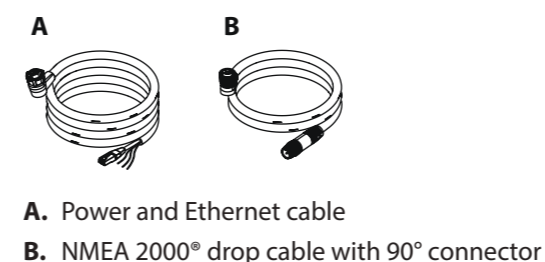

Compliance statement

Declarations

The relevant declarations of conformity are available at:

- www.bandg.com.

Europe

Navico declares under our sole responsibility that the product conforms with the requirements of:

- CE under RED Directive 2014/53/EU.

United States of America

Navico declare under our sole responsibility that the product conforms with the requirements of:

- Part 15 of the FCC Rules. Operation is subject to the following two conditions: (1) this device may not cause harmful interference, and (2) this device must accept any interference received, including interference that may cause undesired operation.

! **Warning:** The user is cautioned that any changes or modifications not expressly approved by the party responsible for compliance could void the user's authority to operate the equipment.

→ **Note:** This equipment generates, uses and can radiate radio frequency energy and, if not installed and used in accordance with the instructions, may cause harmful interference to radio communications. However, there is no guarantee that the interference will not occur in a particular installation. If this equipment does cause harmful interference to radio or television reception, which can be determined by turning the equipment off and on, the user is encouraged to try to correct the interference by one or more of the following measures:

- Reorient or relocate the receiving antenna
- Increase the separation between the equipment and receiver
- Connect the equipment into an outlet on a circuit different from that of the receiver is connected
- Consult the dealer or an experienced technician for help

ISED Canada

This device complies with ISED (Innovation, Science and Economic Development) Canada's license-exempt RSSs. Operation is subject to the following two conditions: (1) This device may not cause interference; and (2) This device must accept any interference, including interference that may cause undesired operation of the device.

La traduction française de ce document est disponible sur le site Web du produit.

Australia and New Zealand

Navico declare under our sole responsibility that the product conforms with the requirements of:

- Level 2 devices of the Radiocommunications (Electromagnetic Compatibility) standard 2017
- Radiocommunications (Short Range Devices) Standards 2014

Trademarks

®Reg. U.S. Pat. & Tm. Off, and ™ common law marks. Visit www.navico.com/intellectual-property to review the global trademark rights and accreditations for Navico Holding AS and other entities.

Mounting

The unit can be mounted in portrait orientation or landscape orientation. In landscape orientation the B&G logo will be in the bottom left corner and in portrait orientation the logo will be in the top left corner.

The unit can be panel mounted or rear mounted. When panel mounted, the unit is mounted in a hole in the surface. When rear mounted, it is mounted on top of the surface.

Refer to the mounting templates for dimensions and details. Rear mounting templates are available on www.bandg.com.

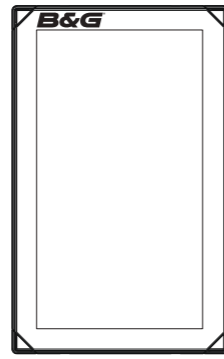

Portrait orientation



Landscape orientation

Wiring

Back connectors

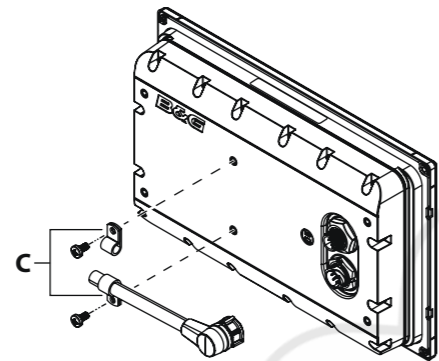
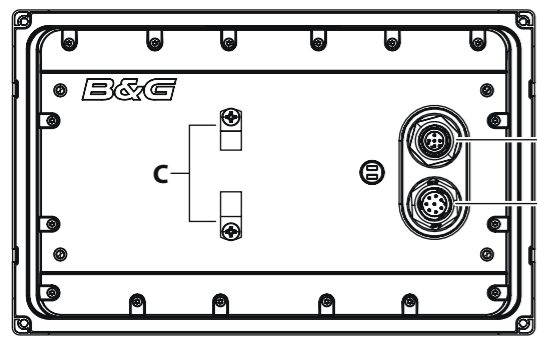

- A. NMEA 2000[®] connector
- B. Power and Ethernet connector
- C. Cable clips for strain relief

Power and Ethernet wiring

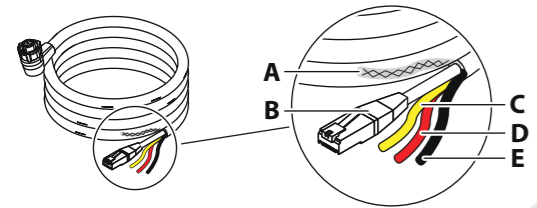

- A. Shield
- B. Ethernet connector (RJ45)
- C. Not used, yellow
- D. +12/24 V DC, red
- E. DC negative, black

Power

The unit is designed to be powered by a 12 or 24 V DC system. It is protected against reverse polarity, under voltage, and over voltage (for a limited duration). A fuse or circuit breaker should be fitted to the positive supply. For recommended fuse rating refer to the technical specifications.

The shield (A) can in most cases be insulated from all other wires. If interference is encountered from other on board electronics, the shield can be connected to a vessel hull ground to help reduce any interference, but it is not generally required.

The yellow wire (B) in the power cable is not to be used and should be insulated from all other wires.

The unit will turn on when power is applied.

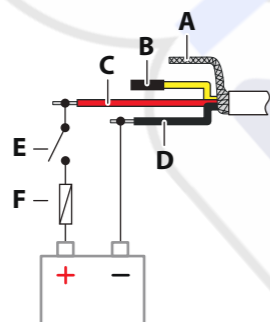

- A. Shield
- B. Not used, yellow
- C. +12/24 V DC, red
- D. DC negative, black
- E. Switch
- F. Fuse

Ethernet

Connect the Ethernet connector to your vessels B&G CPU Ethernet network for transfer of data to the displays.

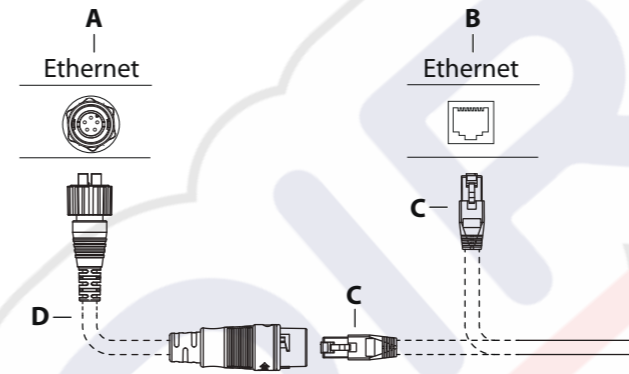

- A. Ethernet switch with a 5-pin Ethernet socket
- B. B&G CPU or Ethernet switch with a RJ45 Ethernet socket
- C. Ethernet cable plug (RJ45)
- D. Ethernet adapter cable (RJ45 to 5-pin), optional

Examples

→ **Note:** Not all cables and necessary accessories are illustrated in the example.

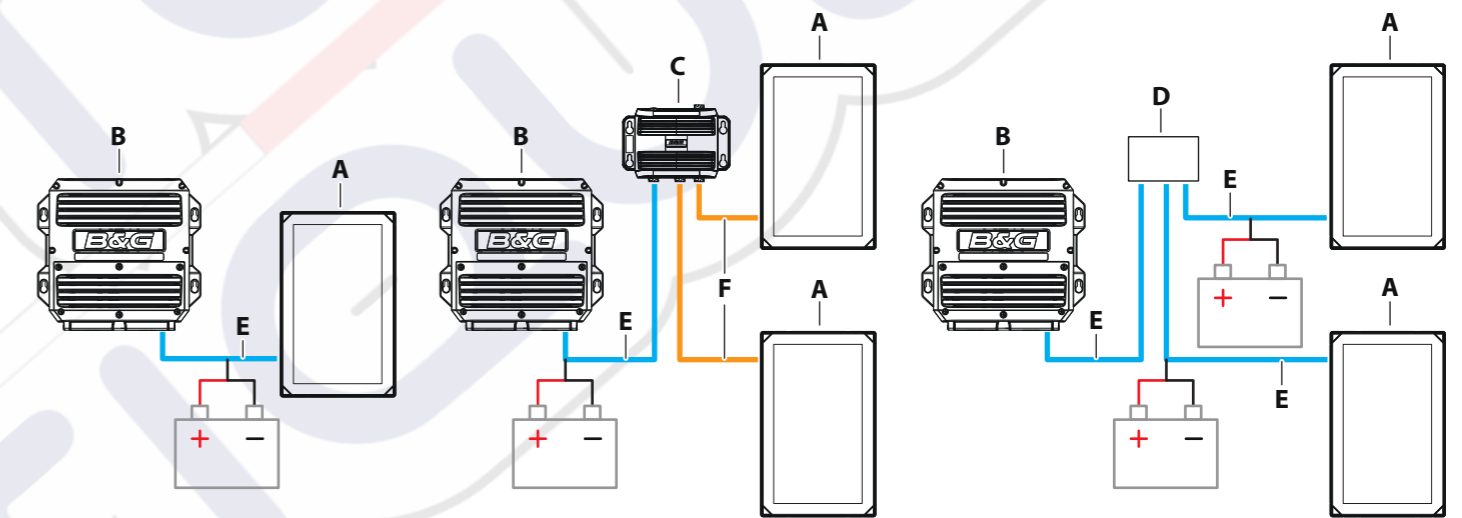

- A. Nemesis™ display
- B. B&G[®] CPU
- C. Nemesis™ hub

- D. Ethernet switch
- E. Power and Ethernet cable
- F. Power and Ethernet connector with connectors at both ends (sold separately)

NMEA 2000[®]

Connect the Nemesis™ display to your vessels NMEA 2000[®] network for transfer of data to the displays.

Example

→ **Note:** Not all cables and necessary accessories are illustrated in the example.

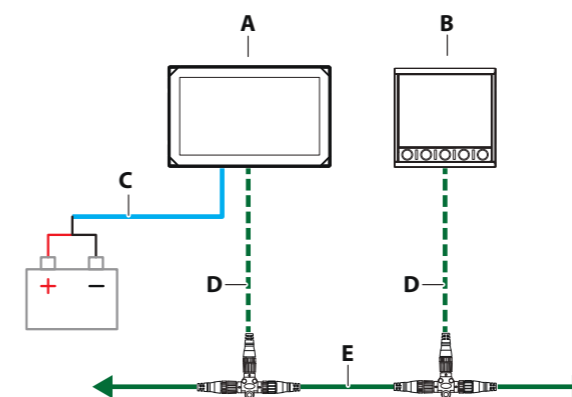

- A. Nemesis™ display
- B. Other NMEA 2000[®] devices
- C. Power and Ethernet cable (used to power the unit)
- D. NMEA 2000[®] drop cables
- E. NMEA 2000[®] backbone

Dimensional drawing

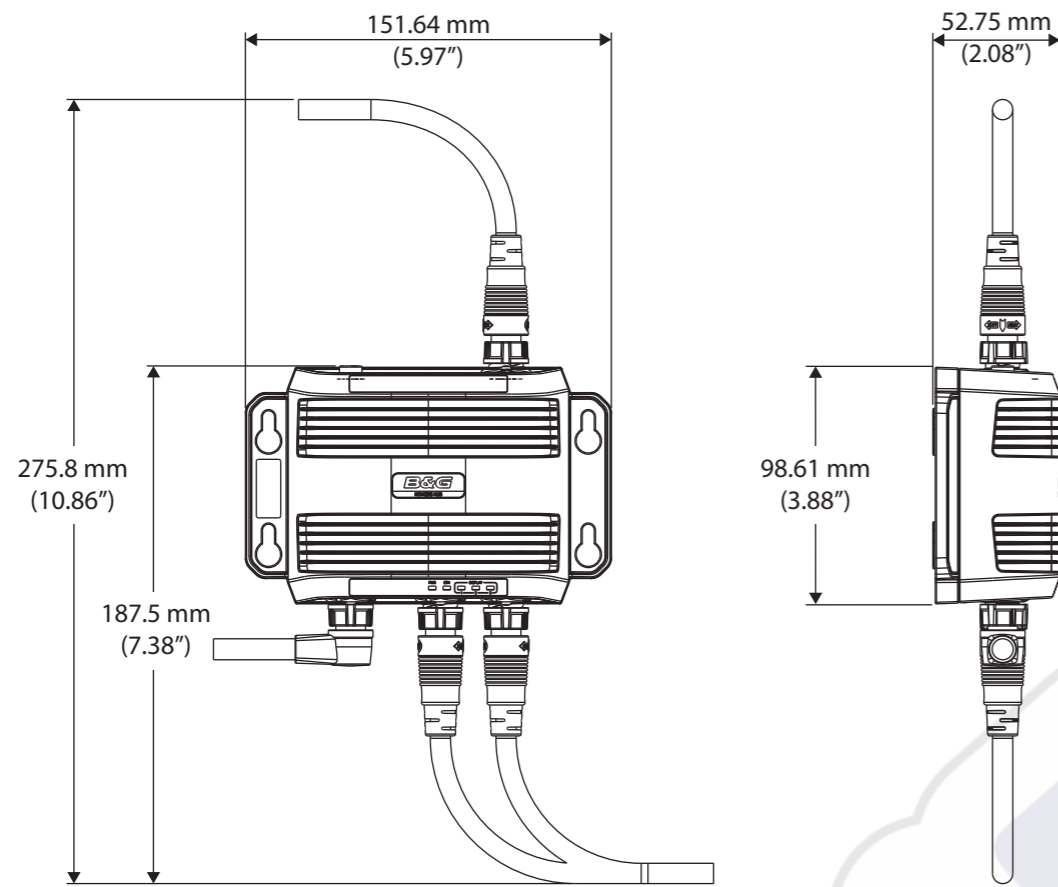

B&G®

NEMESIS™ HUB INSTALLATION GUIDE

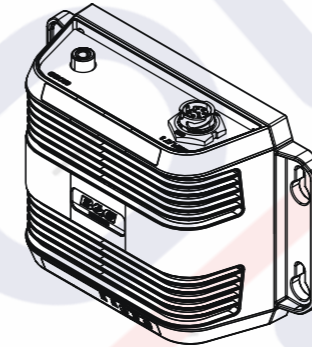

Compliance statement

Declarations

The relevant Declaration of Conformity is available on the following websites:

- www.bandg.com

Europe

Navico declares under our sole responsibility that the product conforms with the requirements of:

- CE under EMC Directive 2014/30/EU

United States of America

→ **Note:** The user is cautioned that any changes or modifications not expressly approved by the party responsible for compliance could void the user's authority to operate the equipment.

Australia and New Zealand

Navico declares under our sole responsibility that the product conforms with the requirements of:

- level 2 devices of the Radiocommunications (Electromagnetic Compatibility) standard 2017

Trademarks

®Reg. U.S. Pat. & Tm. Off, and ™ common law marks. Visit www.navico.com/intellectual-property to review the global trademark rights and accreditations for Navico Holding AS and other entities.

Technical specification

Environmental	
Storage temperature	-15°C to +55°C (5°F to 131°F)
Operating temperature	-20°C to +60°C (4°F to 140°F)
Waterproof rating	IPX 6 and 7
Electrical	
Power supply	12/24 V DC
Operating voltage	12/24 V DC (10 - 31.2 V DC min - max)
Power consumption - Max	2 W + power distributed to connected displays.
Fuse rating	6 A
Physical	
Weight (box only)	240g (0.44 lbs)
Interface/Connectivity	
Ethernet/Power	1x 8-pin connector
Display	3x 8-pin Ethernet connectors
Ground	1x M4 Grounding

Mounting

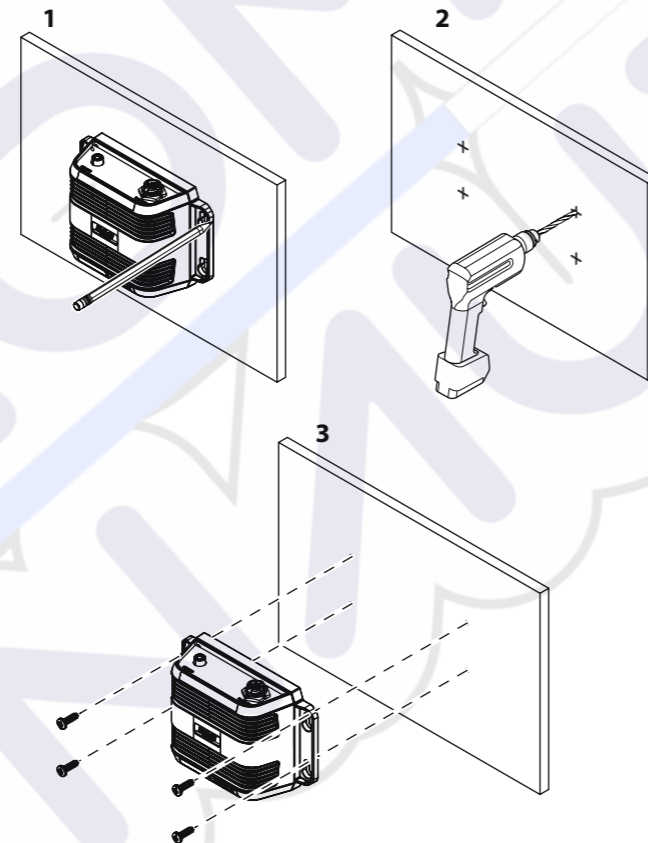

Parts included

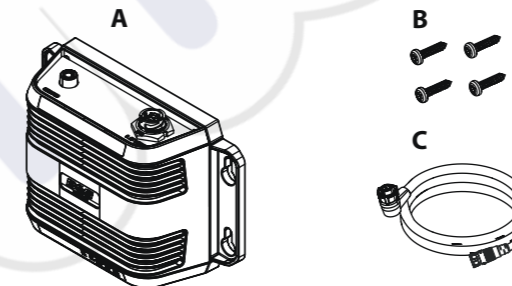

- A. Ethernet switch
- B. Fastening set
- C. Display connection cable
- D. Blanking caps (not shown in the illustration)

Accessories (sold separately)

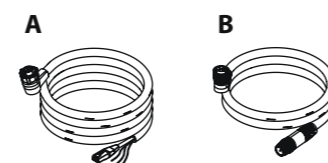

- A. Power and Ethernet cable
- B. Display connector cable

Ethernet and power wiring

- A. Shield
- B. Ethernet connector (RJ45)
- C. Not used, yellow
- D. +12/24 V DC, red
- E. DC negative, black

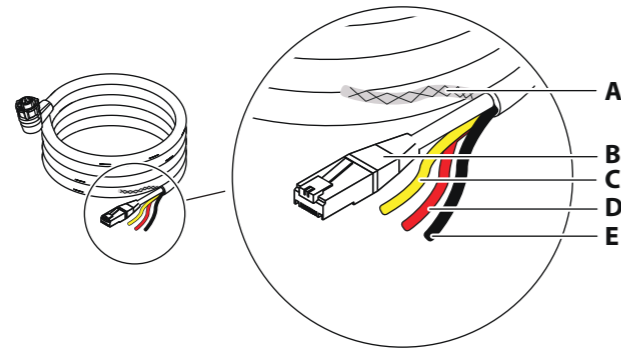

Power

The unit is designed to be powered by 12 or 24 V DC system. It is protected against reverse polarity, under voltage, and over voltage (for a limited duration). A fuse or circuit breaker should be fitted to the positive supply. For recommended fuse rating refer to the technical specifications.

The shield (A) can in most cases be insulated from all other wires. If interference is encountered from other on board electronics, the shield can be connected to a vessel hull ground to help reduce any interference, but it is not generally required.

The yellow wire (B) in the power cable is not to be used and should be insulated from all other wires.

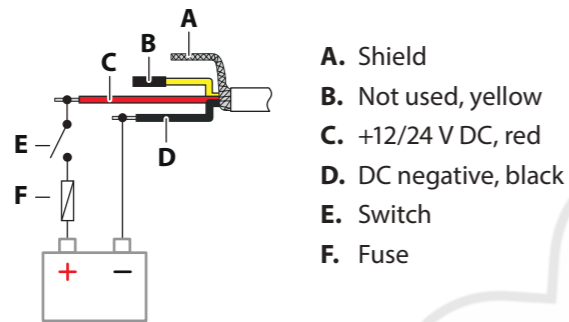

- A. Shield
- B. Not used, yellow
- C. +12/24 V DC, red
- D. DC negative, black
- E. Switch
- F. Fuse

The unit will turn on when power is applied.

Ethernet

Connect the Ethernet connector to your vessels B&G CPU Ethernet network for transfer of data to the displays.

No special setup is required for establishing an Ethernet network.

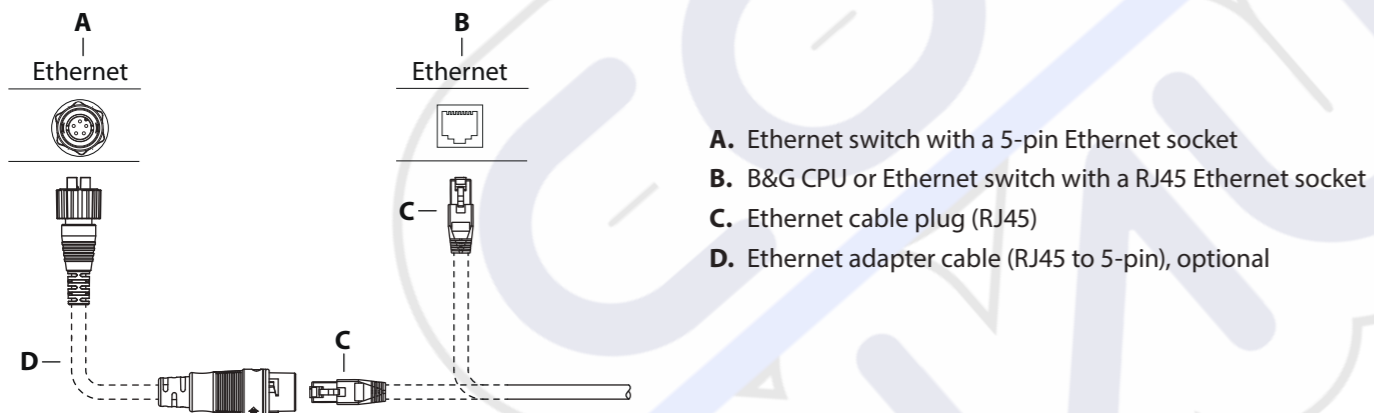

- A. Ethernet switch with a 5-pin Ethernet socket
- B. B&G CPU or Ethernet switch with a RJ45 Ethernet socket
- C. Ethernet cable plug (RJ45)
- D. Ethernet adapter cable (RJ45 to 5-pin), optional

Connectors overview

Bottom connectors

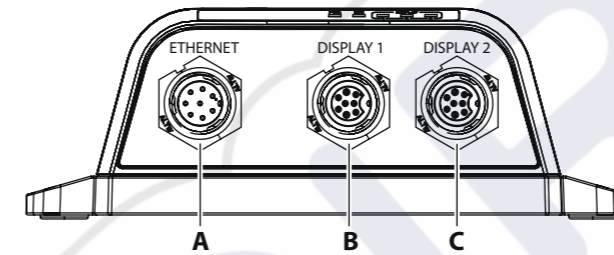

Top connectors

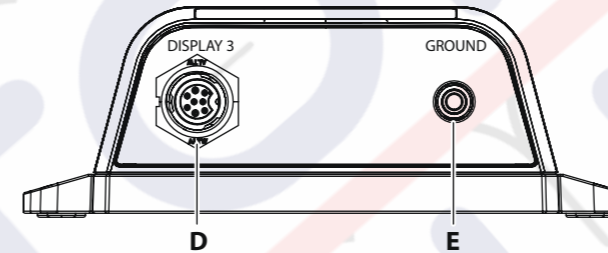

- A. Ethernet - Power and Ethernet connection
- B. Display connector 1
- C. Display connector 2
- D. Display connector 3
- E. Ground, M4

Grounding

It is recommended to ground the unit. 1.5 mm² (16 AWG) wire.

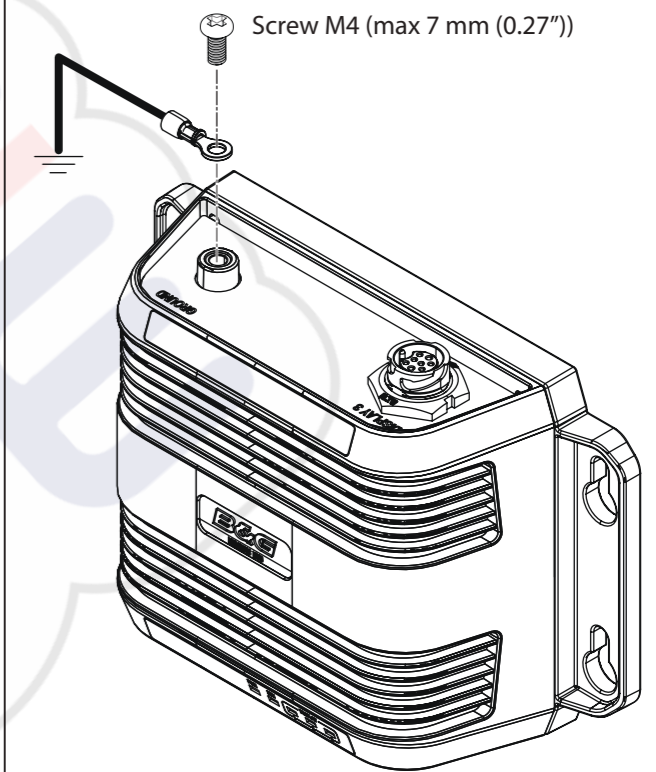

Display wiring

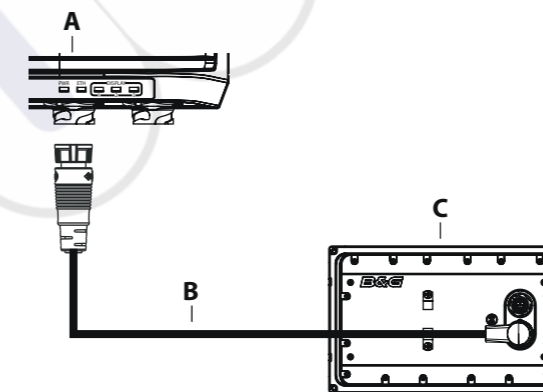

- A. Ethernet switch, display port 1-3
- B. Display power and Ethernet cable
- C. Display

LED indicators

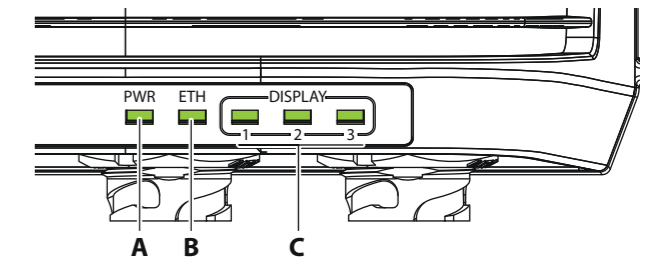

- A. Power (PWR)
The power indicator is lit when the unit is powered.
- B. Ethernet (ETH)
The Ethernet indicator blinks while data is transferred between the hub and the vessels Ethernet network.
- C. Display 1-3
The display indicators blink while data is transferred between the hub and the connected display.